



REVISIONS			
REV.	DESCRIPTION	DATE	APPROVED
A	PRODUCTION RELEASE	1/06/11	K.R.

Nominal Coil Voltage	Part Number	Flange Type
28 Vdc	WR28T1-4321	COVER FLANGE
28 Vdc	WR28T2-4321	CHOKE FLANGE

REVISIONS	A	A	A				 DowKey® Microwave CORPORATION	4822 McGrath Street Ventura, CA. 93003-5641 PH: (805) 650-0260 FAX: (805) 650-1734	
SHEET NO.	1	2	3						
APPROVALS		DATE					 WR28 WAVEGUIDE SWITCH, TRANSFER, LATCHING SELF CUT-OFF, 28 VDC -COMMON, INDICATORS		
DRAWN SARA LEE		1/04/11							
ENGINEERING G. NICKLAUS		1/04/11					CODE IDENT. NO.		
QUALITY S. LYNCH		1/05/11					DWG. NO.		
MANUFACTURING J. LEE		1/06/11					00471		
							WR28TX-4321		
							SCALE NONE		FINAL ASSY:
							SHEET 1 OF 3		

OUTLINE DRAWING:

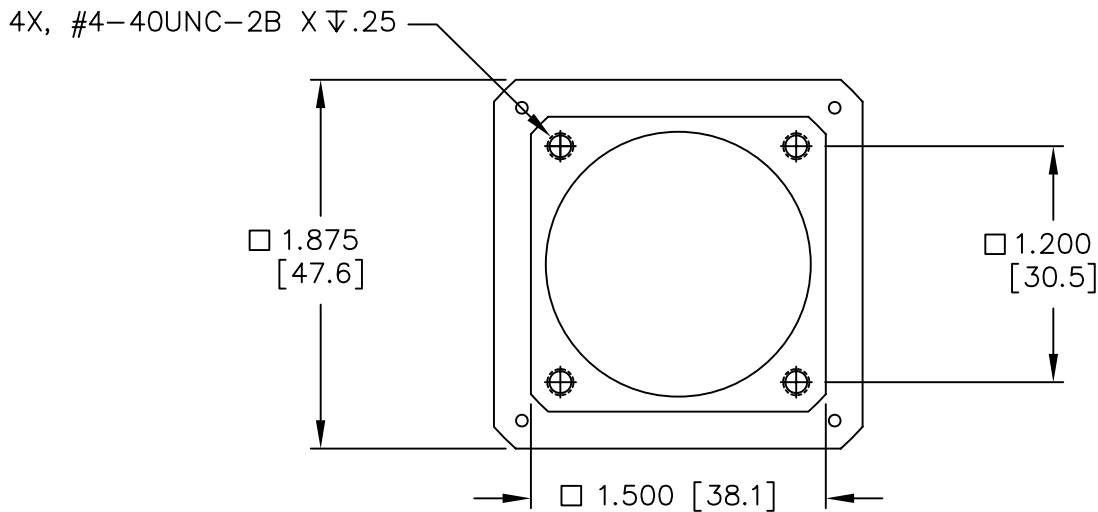
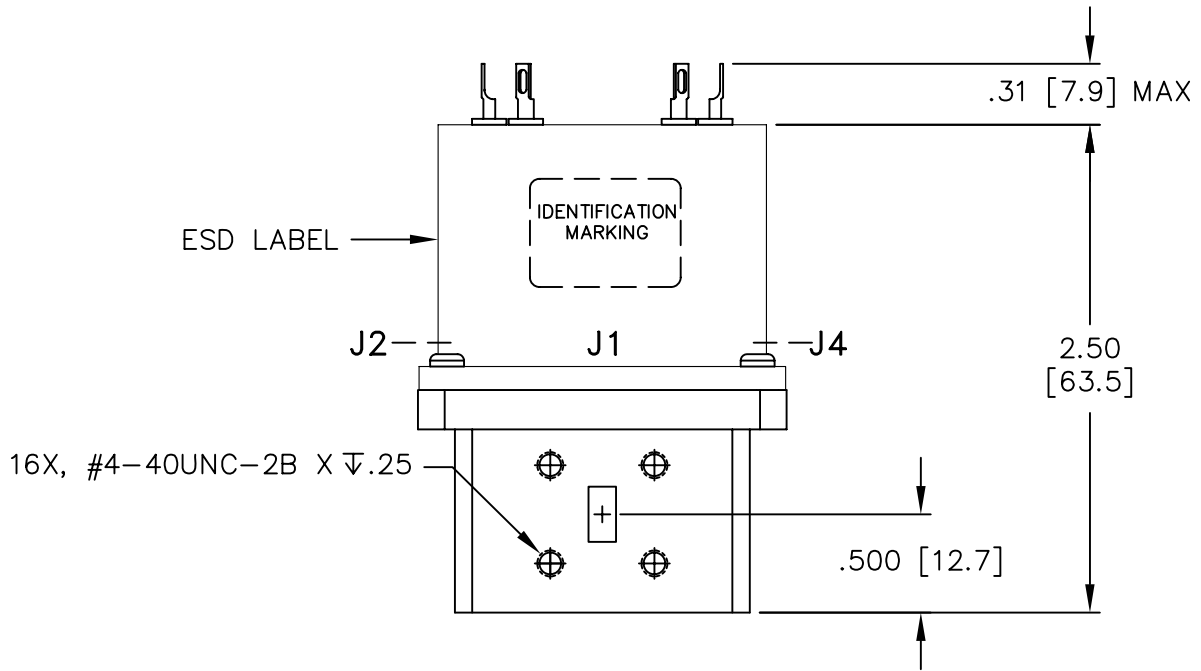
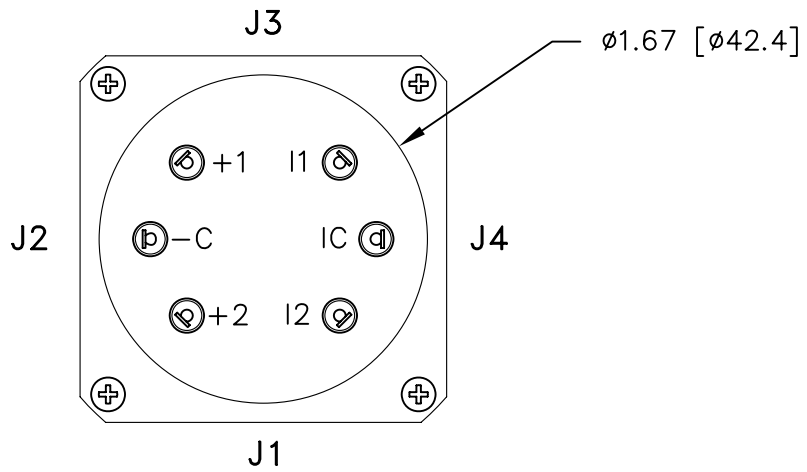

[] MILLIMETERS

UNLESS OTHERWISE SPECIFIED TOLERANCES ARE: .XXX ±.010 ANGLES: ±3° .XX ±.030	CODE IDENT. NO. 00471	DWG. NO. WR28TX-4321	REV. A
	SCALE NONE	SHEET 2 OF 3	

SPECIFICATIONS:

1. RF CHARACTERISTICS:

1.1 FREQUENCY (GHz):	26.5–40.0
1.2 VSWR (RATIO MAX):	1.12:1
1.3 INSERTION LOSS (dB MAX):	0.20
1.4 ISOLATION (dB MIN):	60

2. ACTUATION DATA:

2.1 OPERATING VOLTAGE:	24–30 Vdc (28Vdc NOMINAL)
2.2 OPERATING CURRENT:	.35A MAX @ 28Vdc & 20°C
2.3 SWITCHING TIME:	100ms MAX
2.4 OPERATING MODE:	LATCHING SELF CUT-OFF

3. MECHANICAL:

3.1 WEIGHT:	300g MAX
3.2 DESIGN LIFE:	200,000 CYCLES

4. ENVIRONMENTAL:

4.1 OPERATING TEMPERATURE:	–54°C TO +85°C
4.2 STORAGE TEMPERATURE:	–54°C TO +85°C

5. MATERIALS AND FINISHES:

5.1 RF WAVEGUIDE HOUSING:	ALUMINUM, CHEM FILM
5.2 ACTUATOR HOUSING:	ALUMINUM, ELECTROLESS NICKEL

SCHEMATIC:

SCHEMATIC DIAGRAM (SHOWN IN POS 1)

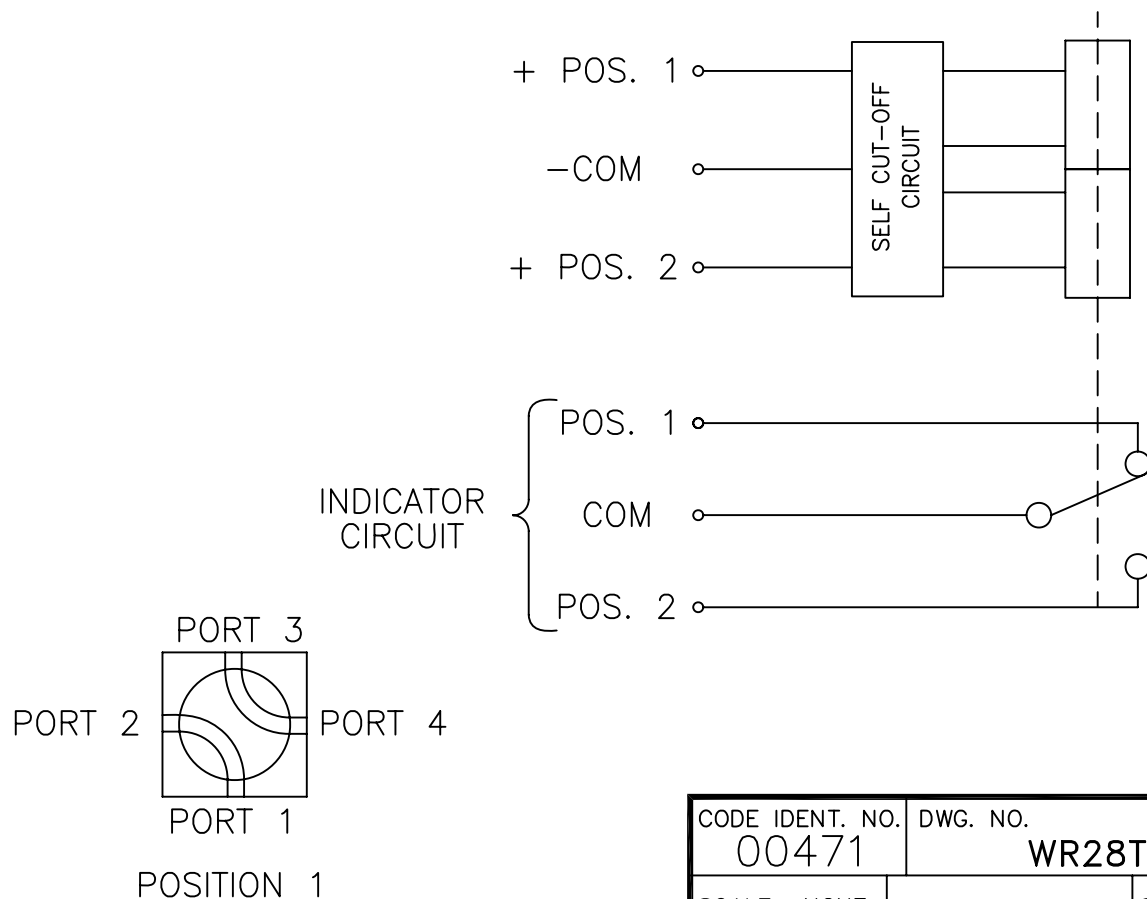

CODE IDENT. NO. 00471	DWG. NO. WR28TX-4321	REV. A
SCALE NONE	SHEET 3 OF 3	