

REVISIONS			
REV.	DESCRIPTION	DATE	APPROVED
A	PRODUCTION RELEASE	5/10/07	K.R.
B	REVISED PER ECO 12812	9/8/22	A.Z.

Nominal Coil Voltage	Part Number		
	SP3T	SP4T	SP6T
12 Vdc	531C-520122	541C-520122	561C-520122
15 Vdc	531C-590122	541C-590122	561C-590122
24 Vdc	531C-580122	541C-580122	561C-580122
28 Vdc	531C-530122	541C-530122	561C-530122

APPROVALS	DATE	 <b>DowKey<sup>®</sup> Microwave CORPORATION</b> <small>A DOVER TECHNOLOGIES COMPANY</small>		4822 McGrath Street Ventura, CA. 93003-5641 PH: (805) 650-0260 FAX: (805) 650-1734	
DRAWN					
SARA LEE	8/26/2022	<b>SWITCH, 3-6 POSITION, NORMALLY OPEN N-FEMALE CONNECTORS, MECH INDICATORS MOUNTING BRACKET</b>			
ENGINEERING					
K. KOH	9/2/2022	CODE IDENT. NO.	DWG. NO.		
QUALITY		<b>00471</b>	<b>5X1C-5X0122</b>		
S. LYNCH	9/2/2022	SCALE	NONE	SHEET 1 OF 3	
MANUFACTURING					
R. GARCIA	9/7/2022				

# OUTLINE DRAWING:

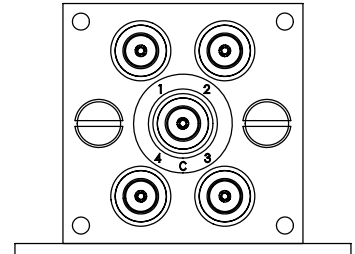
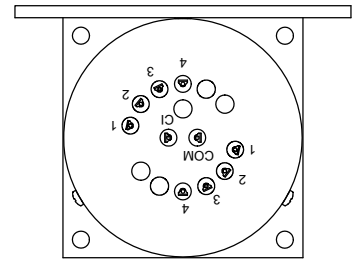
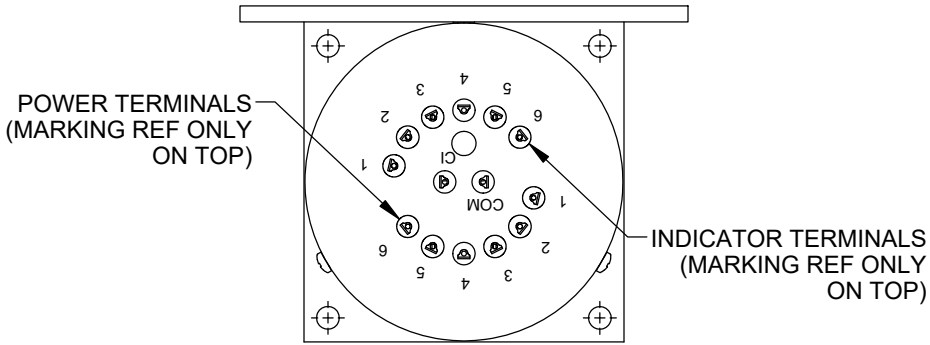

4 POSITION

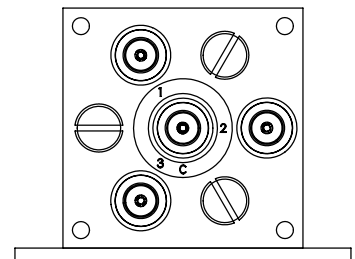
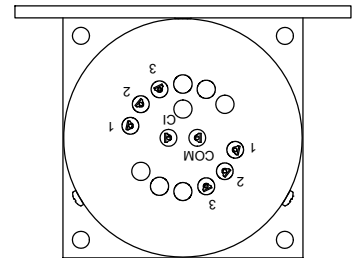

3 POSITION

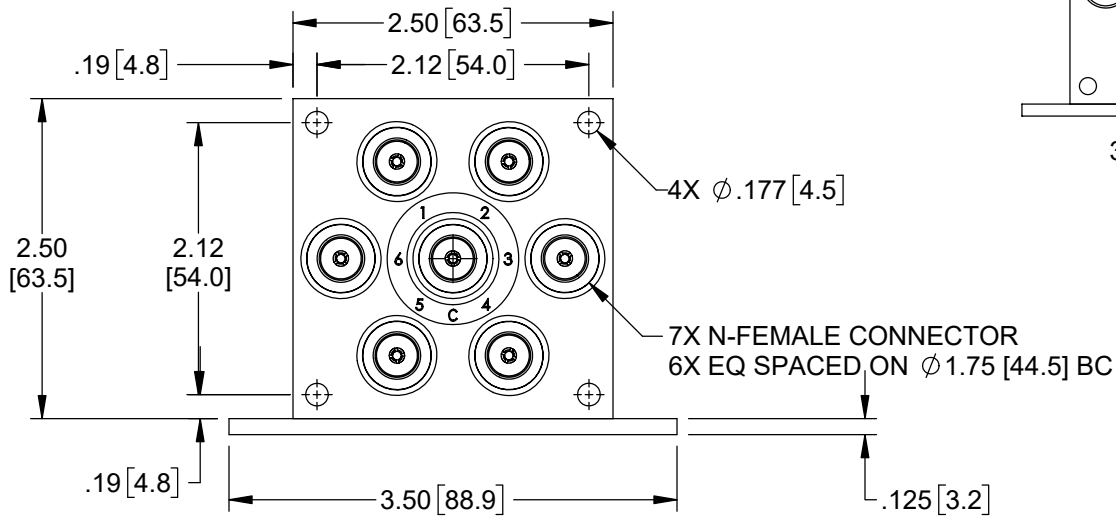
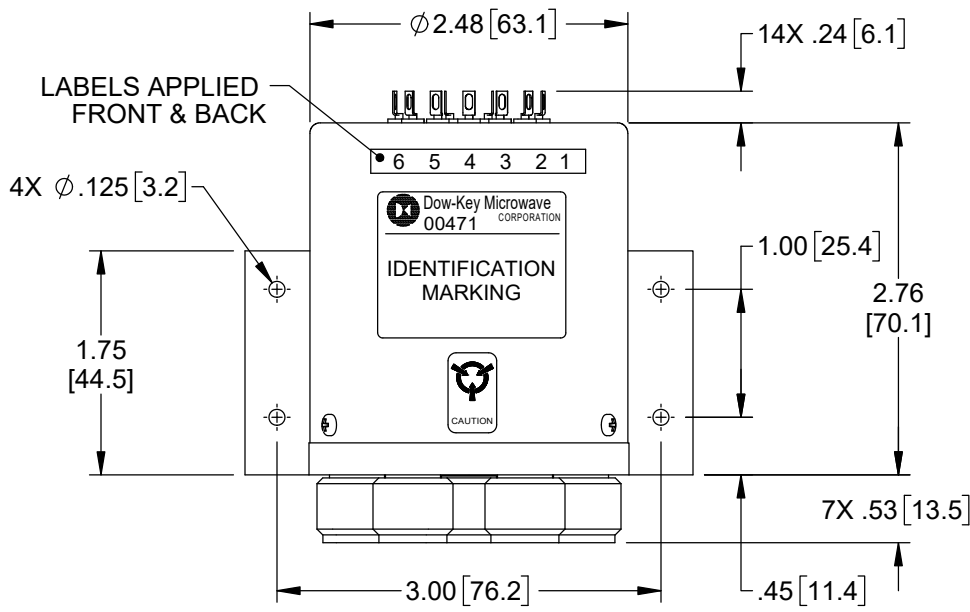

[ ] MILLIMETERS

UNLESS OTHERWISE SPECIFIED TOLERANCES ARE: .XXX ±.010 ANGLES: ±3° .XX ±.030	CODE IDENT. NO. <b>00471</b>	DWG. NO. <b>5X1C-5X0122</b>	REV. <b>B</b>
	SCALE NONE	SHEET 2 OF 3	

# SPECIFICATION:

## 1.0 RF CHARACTERISTICS:

1.1 FREQUENCY (GHz)	DC - 4	4 - 8	8 - 12.4
1.2 VSWR (RATIO MAX)	1.25:1	1.45:1	1.70:1
1.3 INSERTION LOSS (dB MAX)	0.30	0.40	0.70
1.4 ISOLATION (dB MIN)	70	60	55
1.5 RF POWER (WATTS CW MAX) AT SEA LEVEL, +40 °C, LOAD VSWR 1:1	175	125	100
1.6 IMPEDANCE (NOMINAL)	50 OHMS		

## 2.0 ACTUATION DATA:

2.1	NOMINAL VOLTAGE	OPERATING VOLTAGE	CURRENT (NOMINAL) @ NOMINAL VOLTAGE & 25 °C
	12	11-14	100mA
	15	13-17	125mA
	24	20-28	65mA
	28	24-32	55mA

2.2 SWITCHING TIME 20mS MAX  
 2.3 OPERATING MODE NORMALLY OPEN

## 3.0 MECHANICAL:

3.1 CONTACT ARRANGEMENT SP3T, SP4T, SP6T  
 3.2 RF CONTACTS BREAK BEFORE MAKE  
 3.3 WEIGHT 17.0oz (482g) NOMINAL  
 3.4 DESIGN LIFE 1,000,000 CYCLES MINIMUM

## 4.0 ENVIRONMENTAL:

4.1 OPERATING TEMPERATURE -25 °C TO +65 °C  
 4.2 STORAGE TEMPERATURE -55 °C TO +85 °C  
 4.3 SEAL: SAND AND DUST

# SCHMATIC:

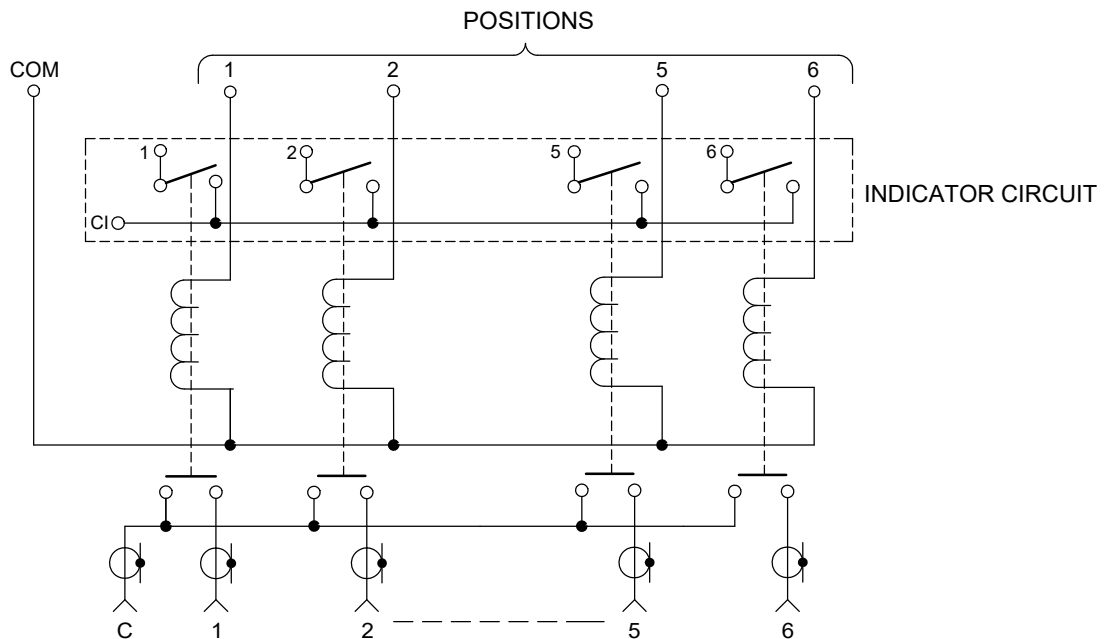

SWITCH SHOWN IN THE DE-ENERGIZED NORMALLY OPEN POSITION

TERMINALS NOT POLARITY SENSITIVE

CODE IDENT. NO. <b>00471</b>	DWG. NO. <b>5X1C-5X0122</b>	REV. <b>B</b>
SCALE NONE	SHEET 3 OF 3	