



**Dow-Key®**  
**Microwave**  
CORPORATION



## **Dow-Key Microwave Product Catalog**

**Our Experience, Your Switch Solution Since 1945**



**MPG**

CONNECTING & PROTECTING

a **DOVER** company

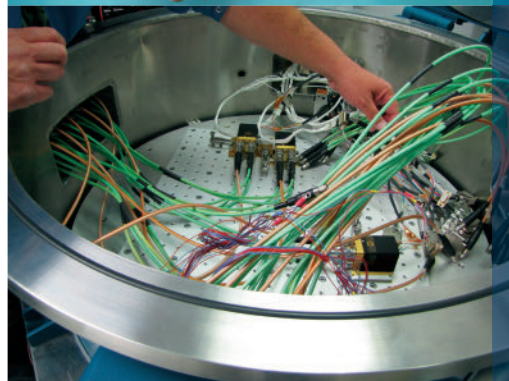
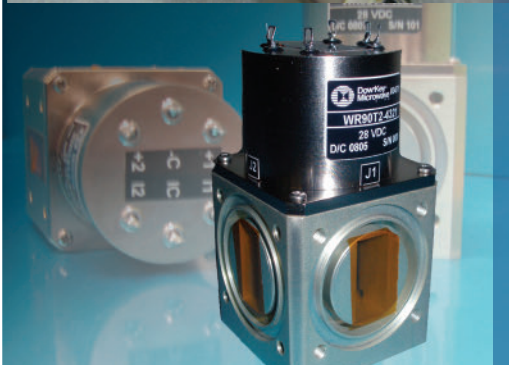

### Our Experience

As the world's largest manufacturer of electromechanical switches, Dow-Key Microwave Corporation is committed to providing unparalleled customer service, competitive pricing, on-time delivery, and products that are distinguished by quality and reliability. Founded in 1945, we are the oldest continuously operating switch manufacturer in the United States. Today, we are part of Microwave Products Group (MPG), a subsidiary of Dover Corporation. Dover is a multi-billion dollar, NYSE-traded, diversified manufacturer of a wide range of proprietary electronic components and systems.

### Quality Assurance

Dow-Key Microwave is a world-class manufacturer with an unparalleled reputation for product quality. Indeed, our space-qualified switches have contributed to the mission success of nearly 100 satellite and launch vehicle programs since 1972. Our commitment to continuous improvement of our products and processes, along with our extensive series of internal and external assessments, ensures compliance with the AS9100 and ISO-9001:2008 standards requirements.

### Advanced Capabilities

Dow-Key Microwave's 36,000-square-foot, state-of-the-art manufacturing facility includes two Class 7 clean rooms in order to support our high-reliability space and military projects. To accomplish the engineering, manufacture, and test of our products and assemblies, we invest heavily in capital equipment. This advanced equipment includes a wide array of vector network analyzers and synthesized sources, noise figure measuring equipment, passive inter-modulation (PIM) test stands, thermal/vacuum chambers, RF power sources, and shock and vibration stations for environmental screening, to name just a few.

### Your Switch Solution

The best in the RF switch industry, Dow-Key Microwave's engineering team is dedicated to supporting customers through product selection, custom-designed solutions, and RF system integration. Whether your organization needs electromechanical switches, automated test equipment, or space-qualified switching arrays, our engineering team works with your specific requirements to create the optimum RF switching solution. Backed by decades of industry experience, our highly skilled technical staff is continuously improving the quality and variety of our product offering based upon customer needs as well as advances in technology. We offer customers the best value solution for their applications, on budget and on time. Since 1945, our experience is your switch solution.

Catalog No: 214

Microwave Products Group (MPG) designs, manufactures and sells special electronic components and systems, including high-performance filters, switches, diplexers and cosite signal interference solutions. Our products are used in military, space, telecom infrastructure, medical and industrial applications where function and reliability are crucial.

[www.mpgdover.com](http://www.mpgdover.com)

# MICROWAVE SWITCHES

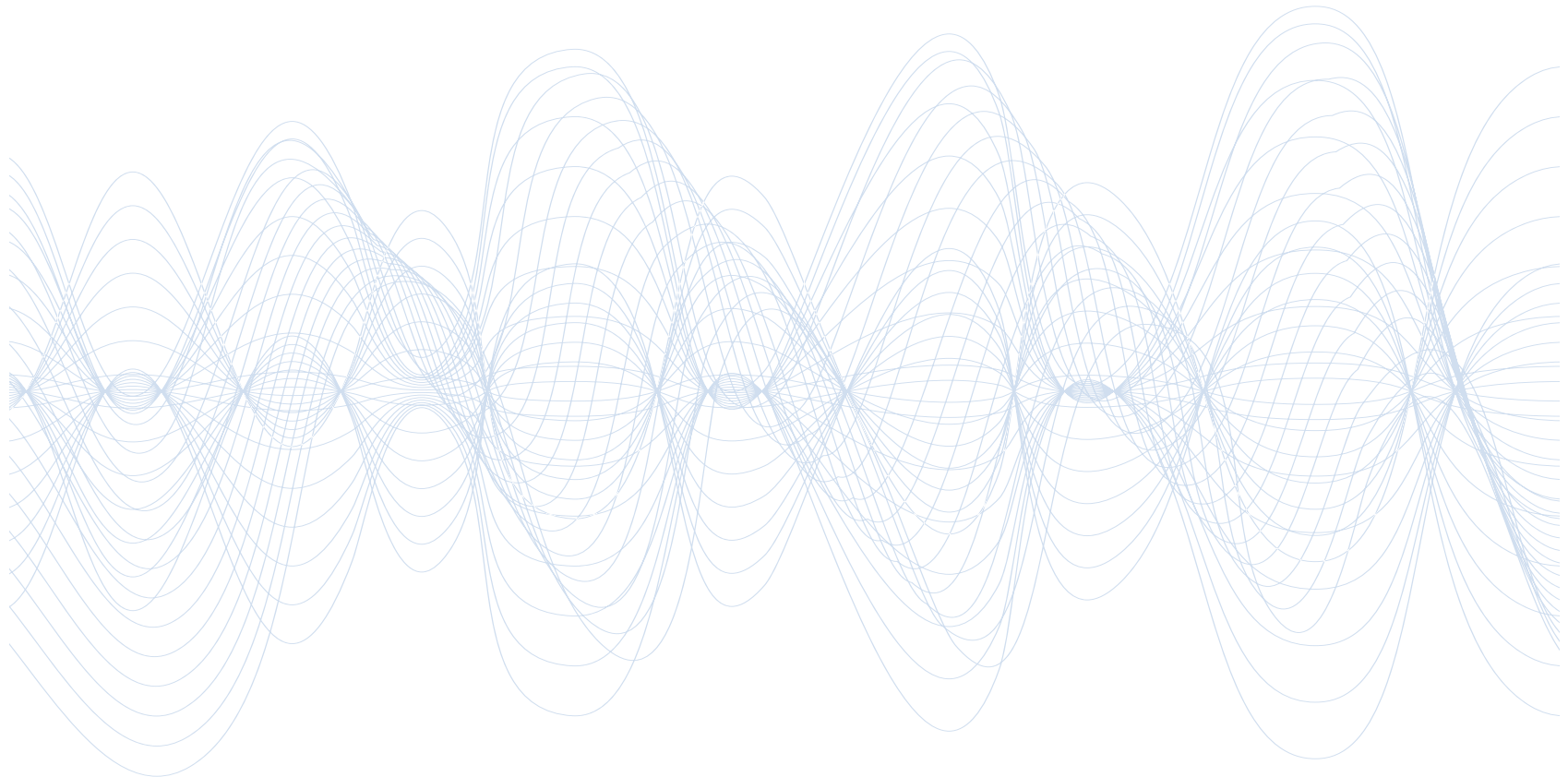

# TABLE OF CONTENTS

	RF Connector/Type	Page
<b>Ordering Information</b>		i
<b>Power Chart: Standard Switches</b>		ii
<b>Dow-Key Part Numbering System</b>		iii
<b>SPDT Coaxial Switches</b>		<b>1-1</b>
SPDT: 401 Failsafe	SMA, 2.9 mm (K)	1-2
SPDT: 401 Latching	SMA, 2.9 mm (K)	1-3
401 Electrical Schematics		1-4
SPDT: 402 Failsafe	N, BNC, TNC, SC	1-5
SPDT: 402 Latching	N, BNC, TNC, SC	1-6
402 Electrical Schematics		1-7
SPDT or 2/3: SPDT: 521U Failsafe Unterminated/Terminated	SMA	1-8
SPDT or 2/3: SPDT: 521U Latching Unterminated/Terminated	SMA	1-9
SPDT or 2/3: SPDT: 521Y Failsafe Unterminated/Terminated	2.9 mm (K)	1-10
SPDT or 2/3: SPDT: 521Y Latching Unterminated/Terminated	2.9 mm (K)	1-11
521U/521Y Electrical Schematics		1-12
<b>DPDT/TRANSFER Coaxial Switches</b>		<b>2-1</b>
DPDT / Bypass DPDT: 411C Failsafe	SMA, 2.9 mm (K)	2-2
DPDT / Bypass DPDT: 411C Latching	SMA, 2.9 mm (K)	2-3
DPDT: 412 Failsafe	N, BNC, TNC, SC	2-4
DPDT: 412 Latching	N, BNC, TNC, SC	2-5
411C/412 Electrical Schematics		2-6
<b>SP3T-SP14T Multiposition Coaxial Switches</b>		<b>3-1</b>
SP3T-SP6T: 535-565 Normally Open	SMA, 2.9mm (K)	3-2
SP3T-SP6T: 431-461 Normally Open Terminated	SMA	3-3
SP3T-SP6T: 431-461 Latching	SMA	3-4
SP3T-SP6T: 431-461 Latching Terminated	SMA	3-5
SP3T-SP6T: 531-561 Normally Open	N, BNC, TNC, SC	3-6
SP3T-SP6T: 531-561 Latching	N, BNC, TNC, SC	3-7
SP3T-SP6T: 531Y-561Y Latching Terminated	2.9 mm (K)	3-8
SP8T: 581 Normally Open	SMA	3-9
SP8T: 581 Normally Open Terminated	SMA	3-10
SP8T: 581 Latching	SMA	3-11
SP8T: 581 Latching Terminated	SMA	3-12
SP10T: 5A1 Normally Open	SMA	3-13
SP10T: 5A1 Normally Open Terminated	SMA	3-14
SP10T: 5A1 Latching	SMA	3-15
SP10T: 5A1 Latching Terminated	SMA	3-16
SP12T: 5C1 Normally Open	SMA	3-17

# TABLE OF CONTENTS

	RF Connector/Type	Page
<b>Multiposition Section (cont.)</b>		
SP12T: 5C1 Latching Underminated/Terminated	SMA	3-18
SP14T: 5E1 Normally Open	SMA	3-19
Normally Open, Underminated / Terminated Electrical Schematics		3-20
Latching, Underminated / Terminated Electrical Schematics		3-21
<b>High Repeatability Reliant™ Coaxial Switches</b>		<b>4-1</b>
SP6T: R461 Latching Terminated	SMA	4-2
<b>Low PIM Coaxial Switches</b>		<b>5-1</b>
SPDT-SP12T: Latching	SMA	5-2
SPDT-SP6T: Latching	N	5-3
<b>Miniature Coaxial Switches</b>		<b>6-1</b>
SP3T-SP6T Miniature: 537-567 Normally Open	SMA	6-2
<b>Waveguide</b>		<b>7-1</b>
SPDT/DPDT Lightweight Waveguide: Latching	WR 28 - WR 112	7-2
<b>Switch Matrix &amp; Space Products Capability Guide</b>		<b>8-1</b>
Switch Matrix Products *		8-2
Space Products *		8-3

\* For more details about these product lines, see Dow-Key's Space Products brochure or Switch Matrix catalog.

# ORDERING INFORMATION

At Dow-Key you are not limited to the products in this catalog, as it is intended to be used as a guide in selecting a switch product or switching matrix for a given application. Requests for modification of standard items and their specifications in order to meet specific needs are always welcome. Inquiries regarding custom integrated components or switch assemblies are also always appreciated.

The catalog is subject to change without notification at any time and new product information is constantly being added in form of press releases through the corporate website at [www.dowkey.com](http://www.dowkey.com). Please visit our website to request quotes, download product materials, for a Sales Representative, and factory contact information.

## Ordering

The information found in this catalog or on [www.dowkey.com](http://www.dowkey.com) should be sufficient for you to select a particular Dow-Key product. In those cases where additional information is required, call Dow-Key directly or our local Dow-Key Sales Representative who will provide you with price and delivery information.

When placing your order, please include the part number, product name, quantity, and shipping instructions. In the case of a non-standard product, a full description of desired features must accompany your order to avoid any error. Send orders to:

Dow-Key Microwave  
4822 McGrath Street  
Ventura, CA 93003 U.S.A.

Or send them in care of our Sales Representative for your area. A complete listing of our Representatives can be found at [www.dowkey.com](http://www.dowkey.com).

Orders will be accepted by way of U.S. mail, telephone, fax, or email. Confirmation of orders on your standard Purchase Order is required.

Telephone: 805.650.0260  
Fax: 805.650.1734  
Email: [askdk@dowkey.com](mailto:askdk@dowkey.com)

## Domestic Terms

Net 30 days, F.O.B. Dow-Key plant, Ventura, California, U.S.A. unless otherwise specified. Shipments made to firms are on a C.O.D. basis unless credit has been established or on receipt of advance payment. American Express, MasterCard and Visa are also accepted.

## Export Terms

Unless other terms have been agreed upon in advance, export terms are either payment in advance of shipment or against a confirmed irrevocable letter of credit. All prices are F.O.B. Ventura, California, U.S.A.

## Shipping

Orders within the United States and Canada will be shipped via United Parcel Service Ground unless other instructions are received. Shipment to all other countries will be by customer direction.

## Packaging

All products shipped from Dow-Key Microwave, Ventura, California are packaged in accordance with best commercial practices unless otherwise specified in the contract or purchase order.

## Delivery

Most standard products are available from stock or within our typical manufacturing lead-time of 1 to 8 weeks after receipt of order.

## Source Inspection

Should Customer Source Inspection of product be required, a charge of \$300.00 per occurrence will apply.

## Application and Technical Assistance

Dow-Key provides a knowledgeable and experienced engineering staff to work closely with customers in product design and application development as well as minor modifications to existing standard products. This service is also available for the design of individual specialized switching components or complex switching systems.

## Warranty

Dow-Key Microwave Corporation warrants all switch products to be free of defects in material and workmanship for a period of one year after the date of initial shipment. The limit of liability under this warranty is to repair, replace or refund purchase price on any product or part thereof that is returned by the purchaser and proves to be defective after examination by Dow-Key. This warranty does not extend to any products mishandled, misused or subjected to abuse or neglect in storage, transportation or use. Repairs or alterations made without consent or knowledge of Dow-Key Microwave Corporation will invalidate this warranty. This warranty supercedes all others, either expressed or implied.

## Return Material Authorization

Please contact Dow-Key to receive a Return Material Authorization (RMA) number prior to returning any item for service. Items returned to Dow-Key without a RMA number are subject to return without evaluation or any work being done. Dow Key will not accept COD freight charges for returned items.

## Dow-Key Terms and Conditions

Dow-Key Microwave Corporation Terms and Conditions apply to all orders unless other provisions have been previously agreed upon. A copy of Dow-Key's Terms and Conditions can be found at [www.dowkey.com](http://www.dowkey.com).

## Certificate of Compliance

If requested at order placement, a certificate of compliance is available upon shipment.

## Minimum Order Amount

Dow-Key's minimum order amount is \$300.00.

## Product Changes

Dow-Key Microwave Corporation continually improves products as new technologies, materials and processes become available. We therefore reserve the right to alter, amend, discontinue, or replace any product and or specifications in this catalog at our sole discretion without prior notice.



# POWER CHART

This chart is based on the following conditions:  
 Ambient Temperature = 40° C; Altitude = Sea Level; VSWR = 1.0:1; Non-switching

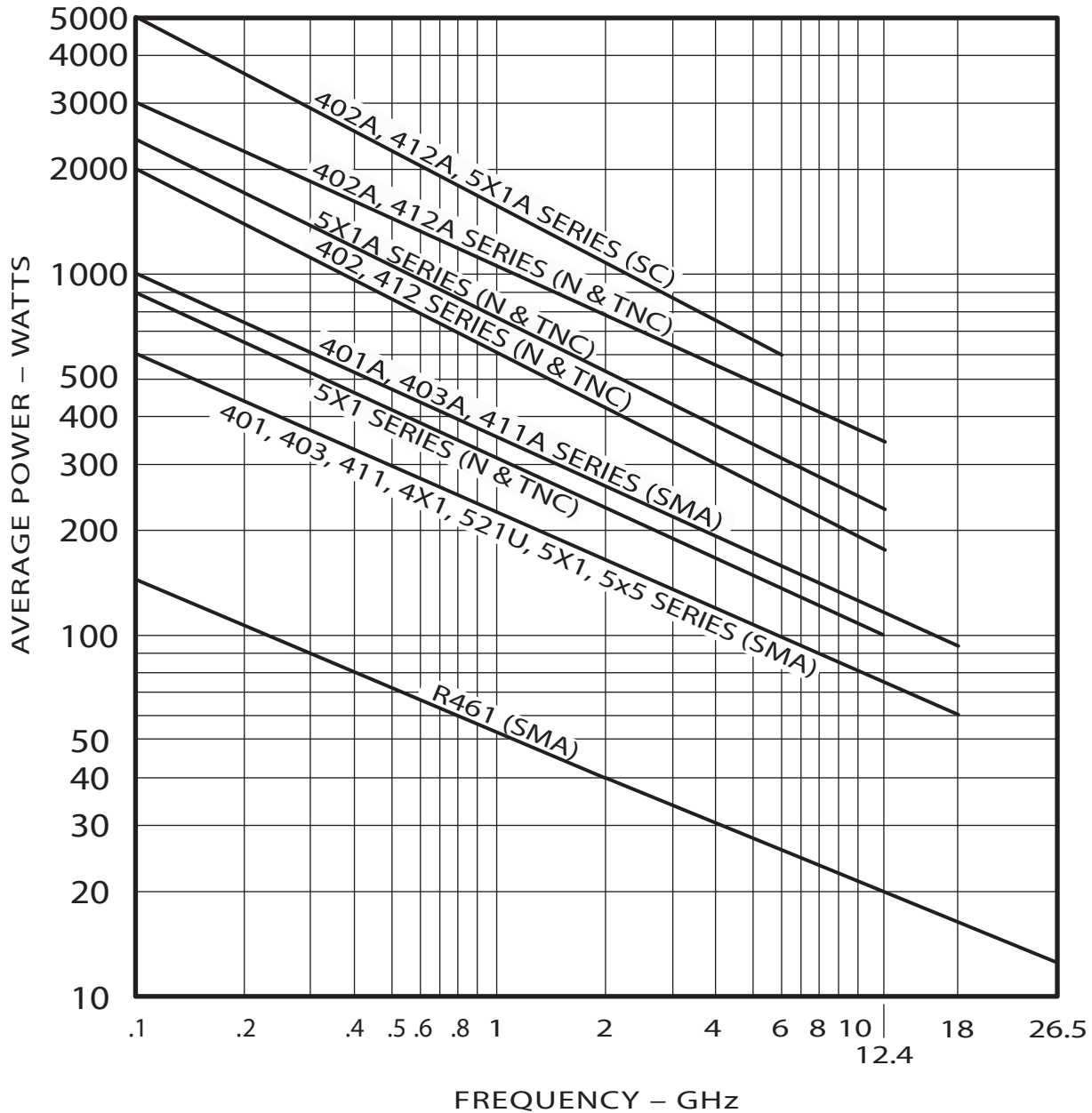

R461-Series is based on the following conditions:  
 Ambient Temperature = 75° C; Altitude = Sea Level; VSWR <1.2:1

*For TRANSCO switches, please consult factory for additional information.*

# PART NUMBERING SYSTEM

## X A B C - D E F G H I J

### (X) RELAY FAMILY

- 4/5 50 Ohm System
- 3 50 Ohm Matrix Multipos.
- 7 70 Ohm System
- R 50 Ohm, Reliant Switch

### (A) CONFIGURATION

- |   |          |   |       |
|---|----------|---|-------|
| 0 | SPDT     | A | SP10T |
| 1 | Transfer | B | SP11T |
| 2 | SPST     | C | SP12T |
| 3 | SP3T     | E | SP14T |
| 4 | SP4T     | F | SP16T |
| 5 | SP5T     |   |       |
| 6 | SP6T     |   |       |
| 7 | SP7T     |   |       |
| 8 | SP8T     |   |       |
| 9 | SP9T     |   |       |

### (B) SIZE

- 1 Std. Case, normally SMA connectors (Radial)
- 2 Std. Case, normally N Connectors
- 3 Small Case, normally SMA (Multithrow)
- 4 Intermediate Cavity, SMA/TNC
- 5 Miniature Radial
- 6 Std. Case, normally N connectors (Radial)
- 7 Microminiature Radial
- 9 Microminiature Switch

### (C) SPECIAL OPTIONS

- |   |                          |   |                                |
|---|--------------------------|---|--------------------------------|
| A | High Power               | K | 26.5 GHz                       |
| B | Bypass (2-4)             | L | Flange Mount Cavity            |
| C | Special Mounting Bracket | M | Fast Switching                 |
| D | Bypass (1-2)             | N | Remove STD Mounting Bracket    |
| E | Bypass (3-4)             | P | Power Connector                |
| F | Bypass (1-3)             | R | Reverse Polarity               |
| G | Make Before Break        | S | Seal, Enhanced Epoxy or Gasket |
| H | HI-REL                   | T | -55°C to +85°C                 |
| I | Immersion Seal           | U | 5 Million Cycles               |
| J | "D" Type Connector       | V | Laser Seal                     |
|   |                          | W | Low PIM                        |
|   |                          | Y | 40 GHz                         |

### (D) ACTUATOR COIL TYPE

- 1 Manual
- 2 Failsafe, Position 1
- 3 Pulse Latching
- 4 Latching, Self Cutoff
- 5 Normally Open
- 6 Failsafe, Suppression Diodes
- 7 Pulse Latching, Suppression Diodes
- 8 Latching Reset, Suppression Diodes
- 9 Normally Open, Suppression Diodes

### (J) SPECIAL OPTIONS

- A TTL HI, Commercial (2.4 - 5.5 Vdc)
- B TTL HI, Military (2.4 - 5.5 Vdc), JANTX
- E CMOS BCD Decoding Logic & MOSFET Driver, Commercial
- G RS-422
- L TTL Logic Low, Commercial (0.0 - 0.8 Vdc)
- N CANBUS
- S Single Line TTL
- T Ethernet
- U USB
- TV Thermal Vacuum

### (I) TERMINATIONS

- |   |       |   |                   |
|---|-------|---|-------------------|
| 1 | Short | 5 | 50Ω, 5W           |
| 2 | Open  | 7 | 50Ω, Term, Port 1 |
| 3 | 50 Ω  | 8 | 50Ω, SMA          |
| 4 | 75 Ω  |   |                   |

### (H) AUXILIARY/INDICATOR CONTACTS

- 0 None
- 2 Mechanical SPST
- 3 Mechanical SPDT
- 5 Optical
- 6 Electronic

### (FG) CONNECTORS

- 01 N
- 02 BNC
- 03 TNC
- 04 UHF
- 05 C
- 06 GPO\*
- 07 BMA (OSP)
- 08 SMA
- 09 3.5mm (SMA Interface)
- 11 2.9mm (K)
- 12 SMB
- 14 TPS
- 19 Pins (PC Board Drop-in)
- 51 HN
- 53 SC
- 54 7/16
- 71 SMB (50 Dhm)
- 72 SMB (75 Dhm)
- 73 SMB (Mini 75 Dhm)

\* GPO is a trademark of Gilbert Engineering

### (E) ACTUATOR COIL VOLTAGE

- |   |        |   |        |
|---|--------|---|--------|
| 0 | Manual | 7 | 20 Vdc |
| 1 | 6 Vdc  | 8 | 24 Vdc |
| 2 | 12 Vdc | 9 | 15 Vdc |
| 3 | 28 Vdc |   |        |
| 4 | 48 Vdc |   |        |
| 5 | 5 Vdc  |   |        |



# SPDT COAXIAL SWITCH

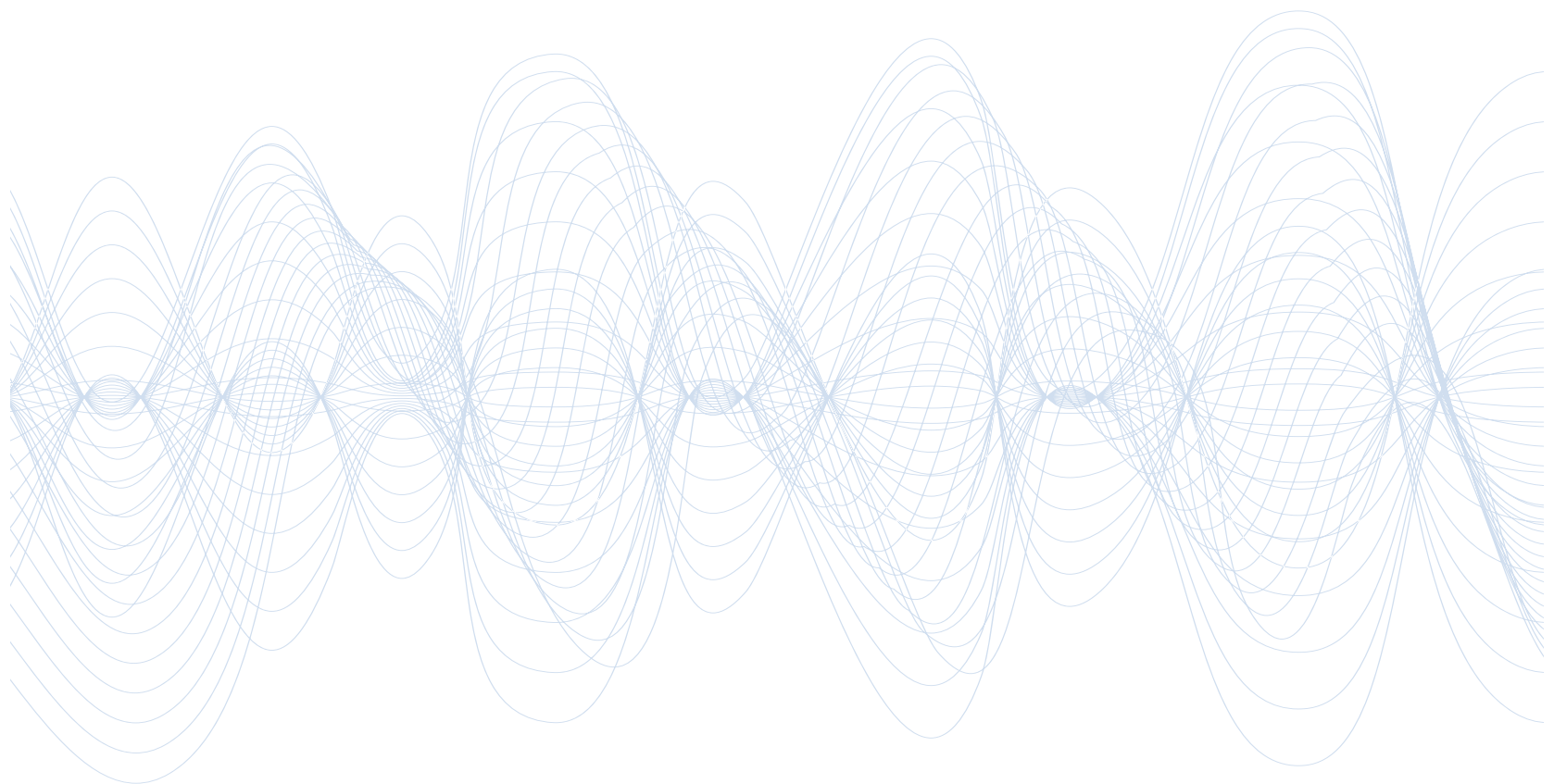

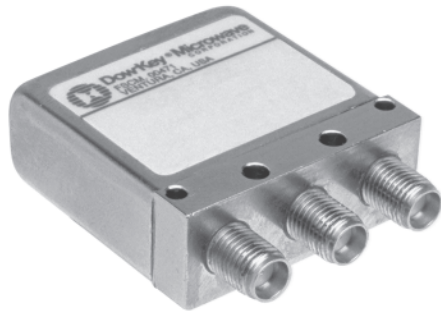

- DC-18 GHz
- DC-26.5 GHz
- DC-40 GHz
- Low/Medium Power
- 1M/5M Life Cycles

## RF Characteristics

Frequency GHz	VSWR (max)	Isolation dB (min)	Ins. Loss dB (max)
DC-1	1.10	85	0.10
1-4	1.15	80	0.15
4-8	1.20	70	0.20
8-12	1.30	65	0.30
12-18	1.35	60	0.35
*18-26.5	1.50	55	0.50
*26.5-40	1.90	55	0.80

\* Performance varies depending on selected options

## Specifications

### Operating Voltage (across temperature range):

- 12 Vdc (11-14 Vdc)
- 24 Vdc (20-28 Vdc)
- 28 Vdc (24-32 Vdc)

### Coil Current (max. @ nom. Vdc & 25°C)\*:

- 12 Vdc 195 mA
- 24 Vdc 125 mA
- 28 Vdc 95 mA

### Switching Time:

15 ms maximum

### Operating Temperature:

- 25°C to +65°C (Standard)
- 55°C to +85°C (Extended "T" Option)

### Mechanical Life Cycles\*:

- 1,000,000 minimum
- 5,000,000 minimum ("U" Option)

### Vibration, Operating:

10G RMS, 20-2000 Hz

### Mechanical Shock, Non-Operating:

30G, 1/2 Sine, 11 ms

### Nominal Weight\*:

1.4 oz. (40 g.)

\* Performance and weight varies depending on selected options. Values listed are for Standard 401 Failsafe model.

## Mechanical

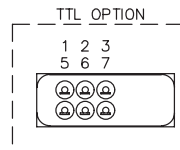

DIM "L" (MAX)	MODEL	ELEC. SCHEM.
1.40 [35.6]	401-2X08	1
1.40 [35.6]	401-2X0832	1
1.80 [45.7]	401-2X0802A	2
1.80 [45.7]	401-2X0832A	2

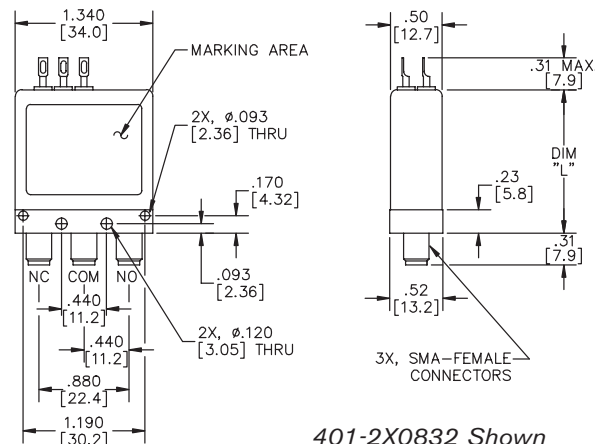

401-2X0832 Shown  
For Electrical Schematic, see page # 1-4

## Part Number Selector

401 J - 2 2 08 02 A - ROHS

Special Options	Actuator	Coil Voltage	Connectors	Indicators	Circuit Options
A = High Power	2 = Failsafe	2 = 12 Vdc	08 = SMA Female	02 = No Indicators*	A = TTL High
I = Immersion Seal	6 = Failsafe with Suppression Diode	3 = 28 Vdc	11 = 2.9 mm (K)	32 = Indicators	L = TTL Low
J = 'D' Connector		8 = 24 Vdc			
K = 26.5 GHz					
S = Epoxy Seal					
T = -55°C to + 85°C					
U = 5M Life Cycles					
Y = 40 GHz					

\* Declared only with Circuit Options

TTL option includes suppression diode. Other options may be available and all combinations may not be possible. Please consult with factory.

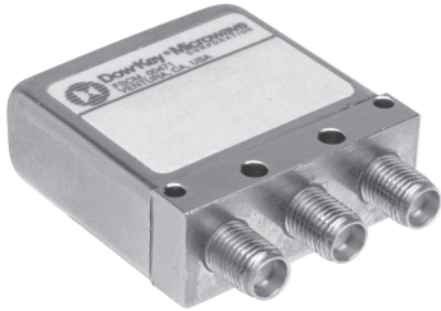

- DC-18 GHz
- DC-26.5 GHz
- DC-40 GHz
- Low/Medium Power
- 1M/5M Life Cycles

## RF Characteristics

Frequency GHz	VSWR (max)	Isolation dB (min)	Ins. Loss dB (max)
DC-1	1.10	85	0.10
1-4	1.15	80	0.15
4-8	1.20	70	0.20
8-12	1.30	65	0.30
12-18	1.35	60	0.35
*18-26.5	1.50	55	0.50
*26.5-40	1.90	55	0.80

\* Performance varies depending on selected options

## Specifications

### Operating Voltage (across temperature range):

- 12 Vdc (11-14 Vdc)
- 24 Vdc (20-28 Vdc)
- 28 Vdc (24-32 Vdc)

### Coil Current (max. @ nom. Vdc & 25°C)\*:

- 12 Vdc 230 mA
- 24 Vdc 135 mA
- 28 Vdc 115 mA

### Switching Time:

15 ms maximum

### Operating Temperature:

- 25°C to +65°C (Standard)
- 55°C to +85°C (Extended "T" Option)

### Mechanical Life Cycles\*:

- 1,000,000 minimum
- 5,000,000 minimum ("U" Option)

### Vibration, Operating:

10G RMS, 20-2000 Hz

### Mechanical Shock, Non-Operating:

30G, 1/2 Sine, 11 ms

### Nominal Weight\*:

1.4 oz. (40 g.)

\* Performance and weight varies depending on selected options. Values listed are for Standard 401 Latching model.

## Mechanical

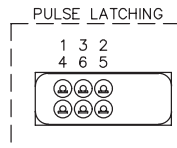

DIM "L" (MAX)	MODEL	ELEC. SCHEM.
1.40 [35.6]	401-3X08	3
1.40 [35.6]	401-3X0832	3
1.80 [45.7]	401-4X08	4
1.80 [45.7]	401-4X0832	4
1.80 [45.7]	401-4X0802A	5
1.80 [45.7]	401-4X0832A	5

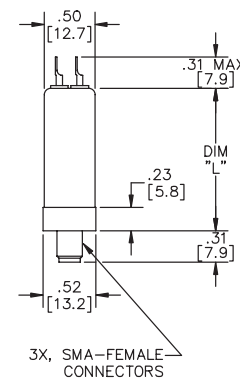
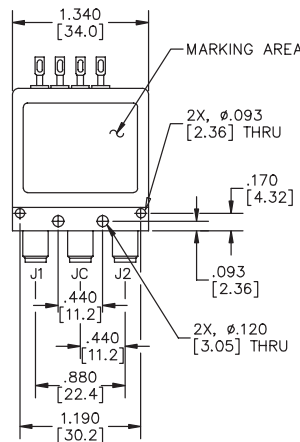

401-4X0832 Shown

For Electrical Schematic, see page # 1-4

## Part Number Selector

401 J - 4 2 08 02 A - ROHS

Special Options	Actuator	Coil Voltage	Connectors	Indicators	Circuit Options
A = High Power	3 = Pulse Latching	2 = 12 Vdc	08 = SMA Female	02 = No Indicators*	A = TTL High
I = Immersion Seal	4 = Latching Self Cutoff	3 = 28 Vdc	11 = 2.9 mm (K)	32 = Indicators	L = TTL Low
J = 'D' Connector	7 = Pulse Latching with Suppression Diode	8 = 24 Vdc			
K = 26.5 GHz					
S = Epoxy Seal					
T = -55°C to + 85°C					
U = 5M Life Cycles					
Y = 40 GHz					

\* Declared only with Circuit Options

TTL option includes suppression diode. Other options may be available and all combinations may not be possible. Please consult with factory.

### 01 401 Failsafe

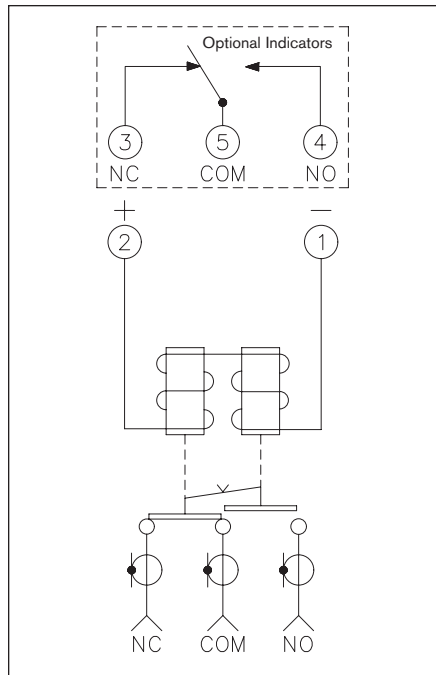

### 02 401 Failsafe TTL

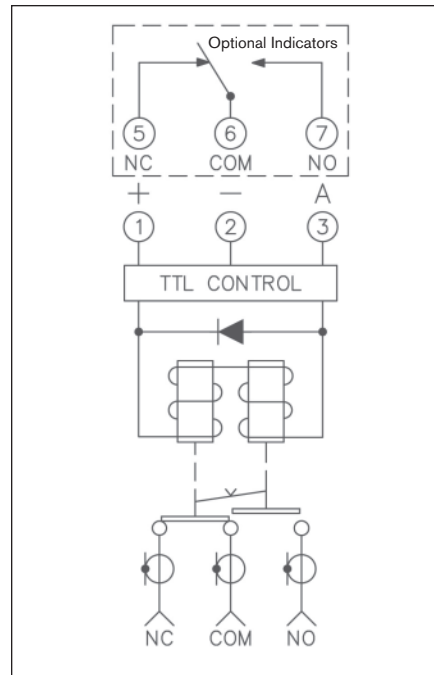

### 03 Logic Truth Table

FAILSAFE TTL - SCH #2

LOGIC TRUTH TABLE		
RF PATH	INDICATOR PATH	LOGIC INPUT "A"
NC-COM	NC-COM	0
NO-COM	NO-COM	1

"0" = 0.0V-0.8V  
"1" = 2.4V-5.5V

SELF CUTOFF TTL - SCH #6

LOGIC TRUTH TABLE			
RF PATH	INDICATOR PATH	LOGIC INPUT "A"	LOGIC INPUT "B"
JC-J1	COM-1	1	0
JC-J2	COM-2	0	1

"0" = 0.0V-0.8V  
"1" = 2.4V-5.5V

### 04 401 Pulse

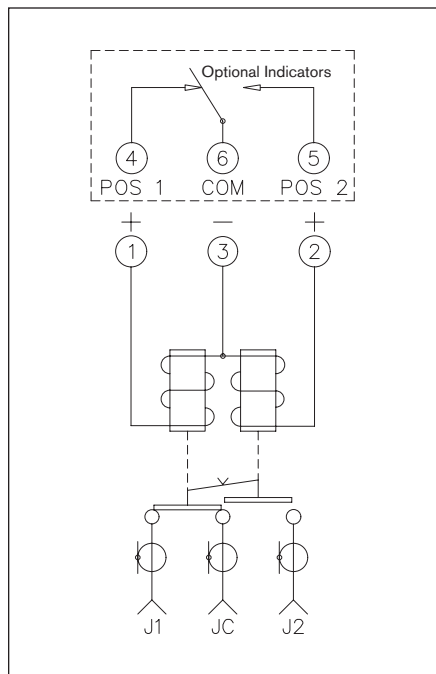

### 05 401 Self Cutoff

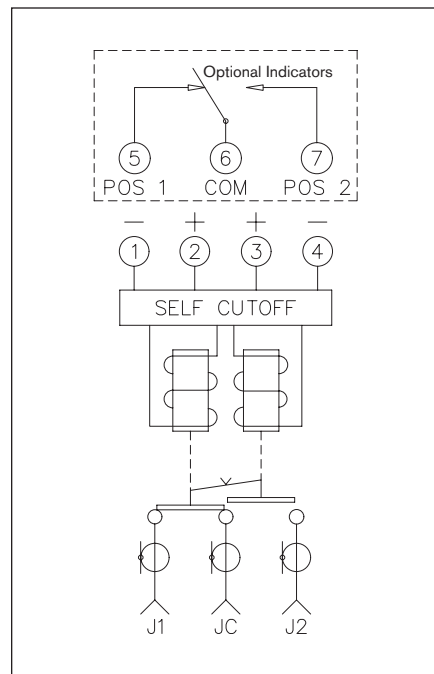

### 06 401 Self Cutoff TTL

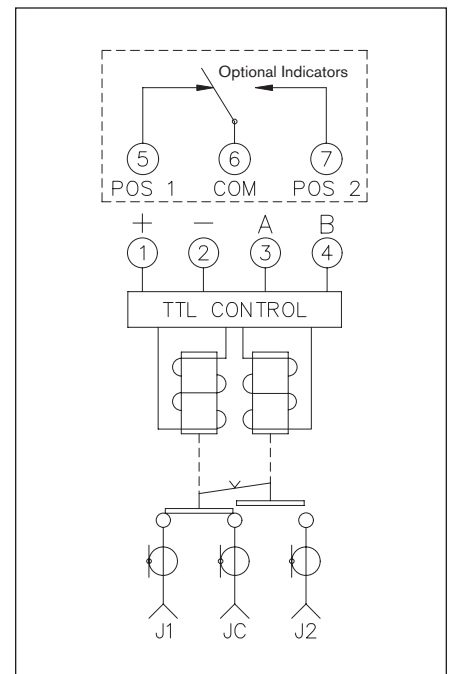



- DC-2 GHz
- DC-6 GHz
- DC-12.4 GHz
- Medium/High Power
- 1M Life Cycles

## RF Characteristics

Frequency GHz	VSWR (max)	Isolation dB (min)	Ins. Loss dB (max)
DC-1	1.15	85	0.15
1-2	1.20	80	0.20
2-4	1.25	70	0.25
4-8	1.45	60	0.40
8-12.4	1.50	60	0.50

Performance applies to N, BNC, and TNC type connectors.  
Consult with factory for SC-type connectors.

## Specifications

### Operating Voltage (across temperature range):

- 12 Vdc (11-14 Vdc)
- 24 Vdc (20-28 Vdc)
- 28 Vdc (24-32 Vdc)

### Coil Current (max. @ nom. Vdc & 25°C)\*:

- 12 Vdc 275 mA
- 24 Vdc 155 mA
- 28 Vdc 115 mA

### Switching Time:

20 ms maximum

### Operating Temperature:

- 25°C to +65°C (Standard)
- 55°C to +85°C (Extended "T" Option)

### Mechanical Life Cycles\*:

1,000,000 minimum

### Vibration, Operating:

10G RMS, 20-2000 Hz

### Mechanical Shock, Non-Operating:

30G, 1/2 Sine, 11 ms

### Nominal Weight\*:

9.0 oz. (255 g.)

\* Performance and weight varies depending on selected options. Values listed are for Standard 402 Failsafe model.

## Mechanical

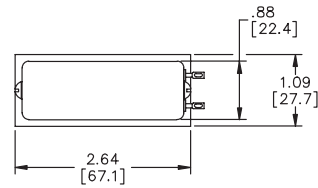

DIM "L" (MAX)	MODEL*	ELEC. SCHEM.
2.30 [58.4]	402-2X01	1
2.30 [58.4]	402-2X0132	1
2.30 [58.4]	402-2X0102A	2
2.30 [58.4]	402-2X0132A	2

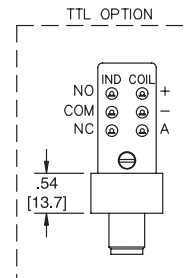
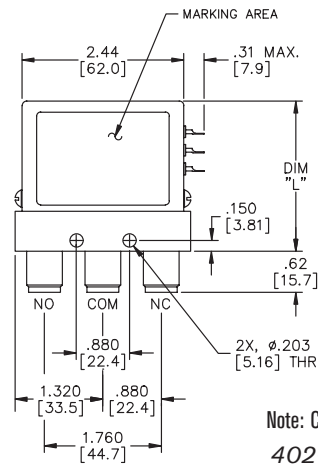

Note: Chart reflects N, BNC, and TNC type of connectors only.  
402-2X0132 Shown  
For Electrical Schematic, see page # 1-7

## Part Number Selector

402 J - 2 2 01 02 A - ROHS

Special Options	Actuator	Coil Voltage	Connectors	Indicators	Circuit Options
A = High Power	2 = Failsafe	2 = 12 Vdc	01 = N Female	02 = No Indicators**	A = TTL High
I = Immersion Seal	6 = Failsafe with Suppression Diode	3 = 28 Vdc	02 = BNC Female	32 = Indicators	L = TTL Low
J = 'D' Connector		8 = 24 Vdc	03 = TNC Female		
P = Power Connector			53 = SC Female*		
S = Epoxy Seal					
T = -55°C to + 85°C					

\* Consult Dow-Key for dimensions

\*\* Declared only with Circuit Options

TTL option includes suppression diode. Other options may be available and all combinations may not be possible. Please consult with factory.



- DC-2 GHz
- DC-6 GHz
- DC-12.4 GHz
- Medium/High Power
- 1M Life Cycles

## RF Characteristics

Frequency GHz	VSWR (max)	Isolation dB (min)	Ins. Loss dB (max)
DC-1	1.15	85	0.15
1-2	1.20	80	0.20
2-4	1.25	70	0.25
4-8	1.45	60	0.40
8-12.4	1.50	60	0.50

Performance applies to N, BNC, and TNC type connectors.  
Consult with factory for SC-type connectors.

## Specifications

### Operating Voltage (across temperature range):

- 12 Vdc (11-14 Vdc)
- 24 Vdc (20-28 Vdc)
- 28 Vdc (24-32 Vdc)

### Coil Current (max. @ nom. Vdc & 25°C)\*:

- 12 Vdc 320 mA
- 24 Vdc 180 mA
- 28 Vdc 135 mA

### Switching Time:

20 ms maximum

### Operating Temperature:

- 25°C to +65°C (Standard)
- 55°C to +85°C (Extended "T" Option)

### Mechanical Life Cycles\*:

1,000,000 minimum

### Vibration, Operating:

10G RMS, 20-2000 Hz

### Mechanical Shock, Non-Operating:

30G, 1/2 Sine, 11 ms

### Nominal Weight\*:

9.0 oz. (255 g.)

\* Performance and weight varies depending on selected options. Values listed are for Standard 402 Latching model.

## Mechanical

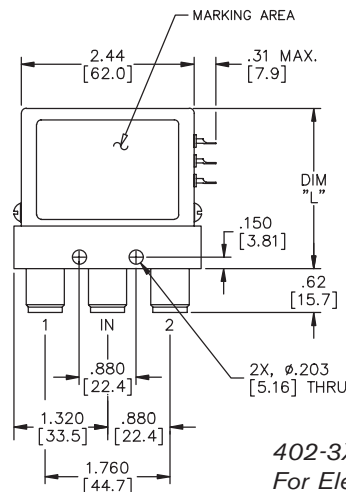
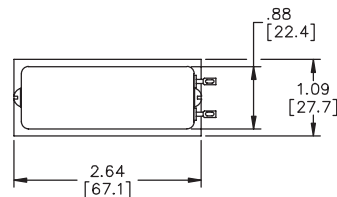

DIM "L" (MAX)	MODEL *	ELEC. SCHEM.
2.30 [58.4]	402-3X01	4
2.30 [58.4]	402-3X0132	4
2.40 [61.0]	402-4X01	5
2.40 [61.0]	402-4X0132	5
2.40 [61.0]	402-4X0102A	6
2.40 [61.0]	402-4X0132A	6

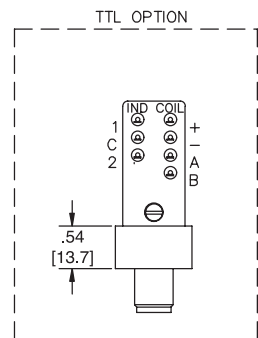

402-3X0132 Shown  
For Electrical Schematic, see page # 1-7

## Part Number Selector

402 J - 4 2 01 02 A - ROHS

Special Options	Actuator	Coil Voltage	Connectors	Indicators	Circuit Options
A = High Power	3 = Pulse Latching	2 = 12 Vdc	01 = N Female	02 = No Indicators**	A = TTL High
I = Immersion Seal	4 = Latching Self Cutoff	3 = 28 Vdc	02 = BNC Female	32 = Indicators	L = TTL Low
J = 'D' Connector	7 = Pulse Latching with Suppression Diodes	8 = 24 Vdc	03 = TNC Female		
P = Power Connector			53 = SC Female*	** Declared only with Circuit Options	
S = Epoxy Seal					
T = -55°C to + 85°C					

\* Consult Dow-Key for dimensions

TTL option includes suppression diode. Other options may be available and all combinations may not be possible. Please consult with factory.

### 01 402 Failsafe

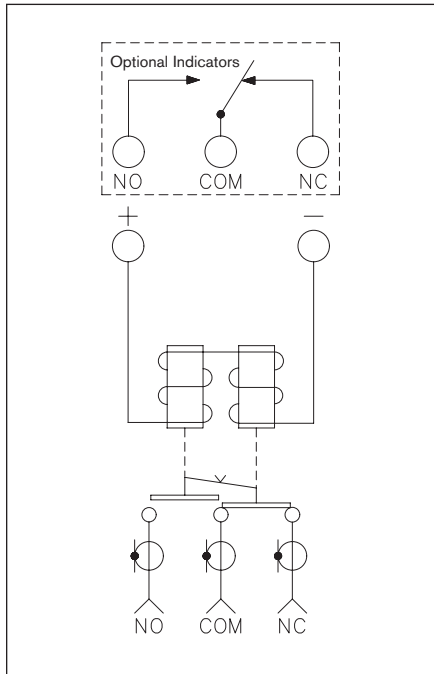

### 02 402 Failsafe TTL

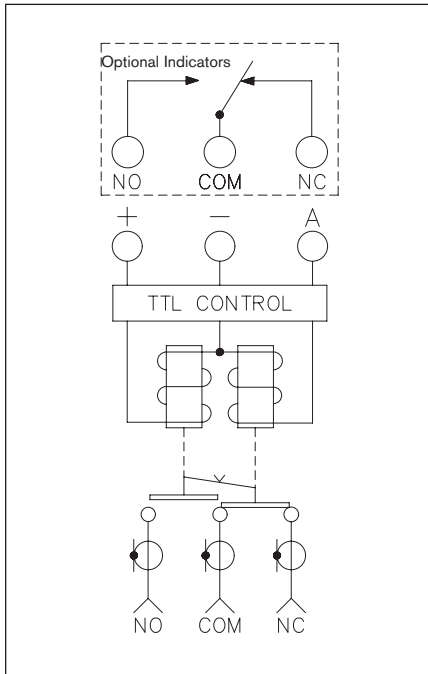

### 03 Logic Truth Table

FAILSAFE TTL - SCH #2

LOGIC TRUTH TABLE		
RF PATH	INDICATOR PATH	LOGIC INPUT "A"
NC-COM	NC-COM	0
NO-COM	NO-COM	1

"0" = 0.0V-0.8V  
 "1" = 2.4V-5.5V

SELF CUTOFF TTL - SCH #6

LOGIC TRUTH TABLE			
RF PATH	INDICATOR PATH	LOGIC INPUT "A"	LOGIC INPUT "B"
IN-1	COM-1	1	0
IN-2	COM-2	0	1

"0" = 0.0V-0.8V  
 "1" = 2.4V-5.5V

### 04 402 Pulse

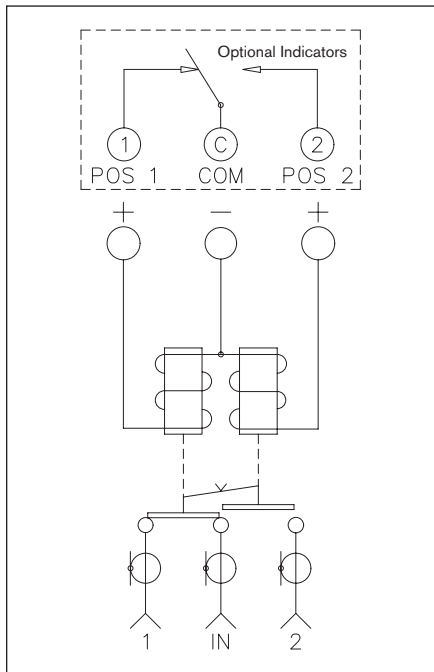

### 05 402 Self Cutoff

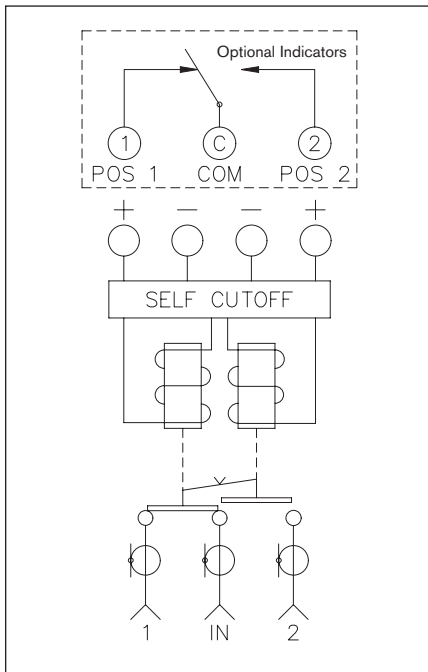

### 06 402 Self Cutoff TTL

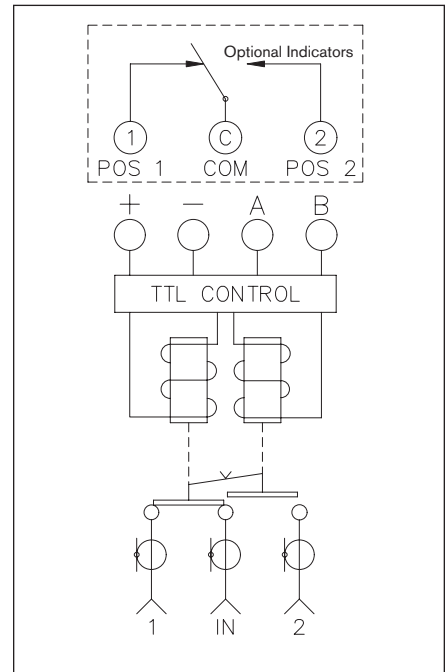



- DC-18 GHz
- DC-26.5 GHz
- Low/Medium Power
- 5M Life Cycles

## RF Characteristics

Frequency GHz	VSWR (max)	Isolation dB (min)	Ins. Loss dB (max)
DC-1	1.10	85	0.10
1-4	1.15	80	0.15
4-8	1.20	70	0.20
8-12	1.30	65	0.30
12-18	1.35	60	0.35
*18-26.5	1.50	55	0.50

\* Performance varies depending on selected options

## Specifications

### Operating Voltage (across temperature range):

- 12 Vdc (11-14 Vdc)
- 24 Vdc (20-28 Vdc)
- 28 Vdc (24-32 Vdc)

### Coil Current (max. @ nom. Vdc & 25°C)\*:

- 12 Vdc 450 mA
- 24 Vdc 225 mA
- 28 Vdc 200 mA

### Switching Time:

- 15 ms maximum

### Operating Temperature:

- 25°C to +65°C (Standard)
- 55°C to +85°C (Extended "T" Option)

### Mechanical Life Cycles:

- 5,000,000 minimum

### Vibration, Operating:

- 10G RMS, 20-2000 Hz

### Mechanical Shock, Non-Operating:

- 30G, 1/2 Sine, 11 ms

### Nominal Weight\*:

- 2.5 oz. (71 g.)

\* Performance and weight varies depending on selected options.

## Mechanical

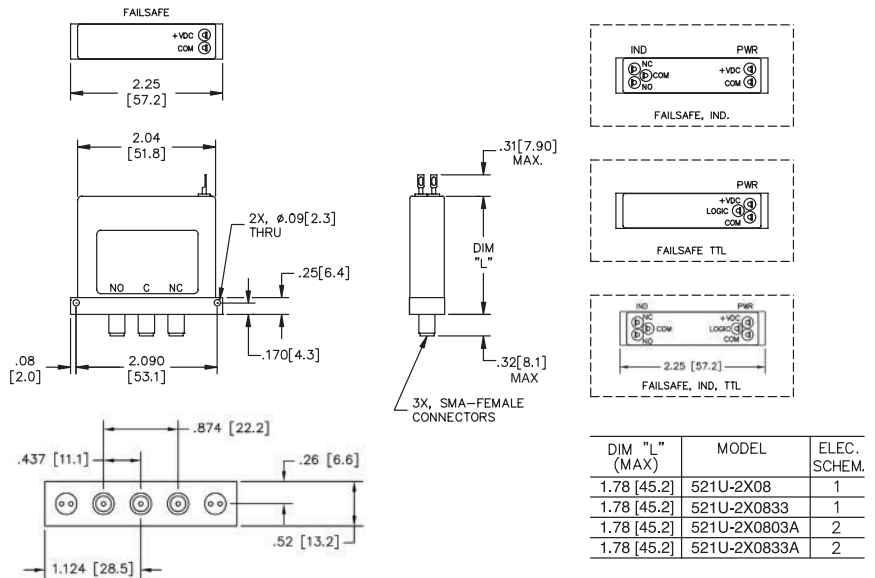

521U-2X0803 Shown

For Electrical Schematic, see page # 1-12

## Part Number Selector

521 J U - 2 2 08 03 A - ROHS

Special Options	Actuator	Coil Voltage	Connectors	Indicators	Circuit Options
I = Immersion Seal	2 = Failsafe	2 = 12 Vdc	08 = SMA Female	02 = No Indicators, Unterminated Ports*	A = TTL High
J = 'D' Connector	6 = Failsafe with Suppression Diode	3 = 28 Vdc		03 = No Indicators, 2W Terminations	L = TTL Low
K = 26.5 GHz		8 = 24 Vdc		**32 = Indicators, Unterminated Ports	* Declared only with Circuit Options
R = (+) Com				**33 = Indicators, 2W Terminations	** Offered with 1M Life Cycles 521-Series
T = -55°C to +85°C					

TTL option includes suppression diode. Other options may be available and all combinations may not be possible. Please consult with factory.





- DC-18 GHz
- DC-26.5 GHz
- Low/Medium Power
- 5M Life Cycles

## RF Characteristics

Frequency GHz	VSWR (max)	Isolation dB (min)	Ins. Loss dB (max)
DC-1	1.10	85	0.10
1-4	1.15	80	0.15
4-8	1.20	70	0.20
8-12	1.30	65	0.30
12-18	1.35	60	0.35
*18-26.5	1.50	55	0.50

\* Performance varies depending on selected options

## Specifications

### Operating Voltage (across temperature range):

- 12 Vdc (11-14 Vdc)
- 24 Vdc (20-28 Vdc)
- 28 Vdc (24-32 Vdc)

### Coil Current (max. @ nom. Vdc & 25°C)\*:

- 12 Vdc 265 mA
- 24 Vdc 205 mA
- 28 Vdc 175 mA

### Switching Time:

15 ms maximum

### Operating Temperature:

- 25°C to +65°C (Standard)
- 55°C to +85°C (Extended "T" Option)

### Mechanical Life Cycles\*:

5,000,000 minimum

### Vibration, Operating:

10G RMS, 20-2000 Hz

### Mechanical Shock, Non-Operating:

30G, 1/2 Sine, 11 ms

### Nominal Weight\*:

2.5 oz. (71 g.)

\* Performance and weight varies depending on selected options.

## Mechanical

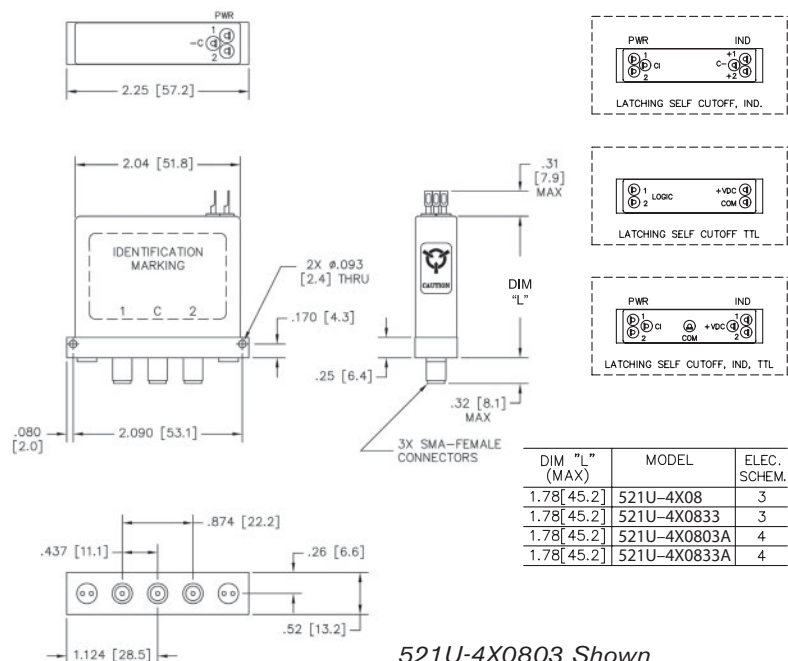

521U-4X0803 Shown

For Electrical Schematic, see page # 1-12

## Part Number Selector

521 **J** **U** - **4** **2** **08** **03** **A** - **ROHS**

Special Options	Actuator	Coil Voltage	Connectors	Indicators	Circuit Options
I = Immersion Seal	3 = Pulse Latching	2 = 12 Vdc	08 = SMA Female	02 = No Indicators, Unterminated Ports*	A = TTL High
J = 'D' Connector	4 = Latching Self Cutoff	3 = 28 Vdc		03 = No Indicators, 2W Terminations	L = TTL Low
K = 26.5 GHz		8 = 24 Vdc		**32 = Indicators, Unterminated Ports	* Declared only with Circuit Options
R = (+) Com				**33 = Indicators, 2W Terminations	** Offered with 1M Life Cycles 521-Series
T = -55°C to +85°C					

TTL option includes suppression diode. Other options may be available and all combinations may not be possible. Please consult with factory.



- DC-40 GHz
- Low Power
- 1M Life Cycles

## RF Characteristics

Frequency GHz	VSWR (max)	Isolation dB (min)	Ins. Loss dB (max)
DC-6	1.30	80	0.30
6-12	1.40	70	0.40
12-18	1.50	65	0.50
18-26.5	1.70	60	0.70
26.5-40	1.80	55	0.80

## Specifications

### Operating Voltage (across temperature range):

- 12 Vdc (11-14 Vdc)
- 28 Vdc (24-32 Vdc)

### Coil Current (max. @ nom. Vdc & 25°C)\*:

- 12 Vdc 450 mA
- 24 Vdc 225 mA
- 28 Vdc 200 mA

### Switching Time:

- 20 ms maximum

### Operating Temperature:

- 25°C to +65°C (Standard)
- 55°C to +85°C (Extended "T" Option)

### Mechanical Life Cycles\*:

- 1,000,000 minimum

### Vibration, Operating:

- 10G RMS, 20-2000 Hz

### Mechanical Shock, Non-Operating:

- 30G, 1/2 Sine, 11 ms

### Nominal Weight\*:

- 2.5 oz. (71 g.)

\* Performance and weight varies depending on selected options.

## Mechanical

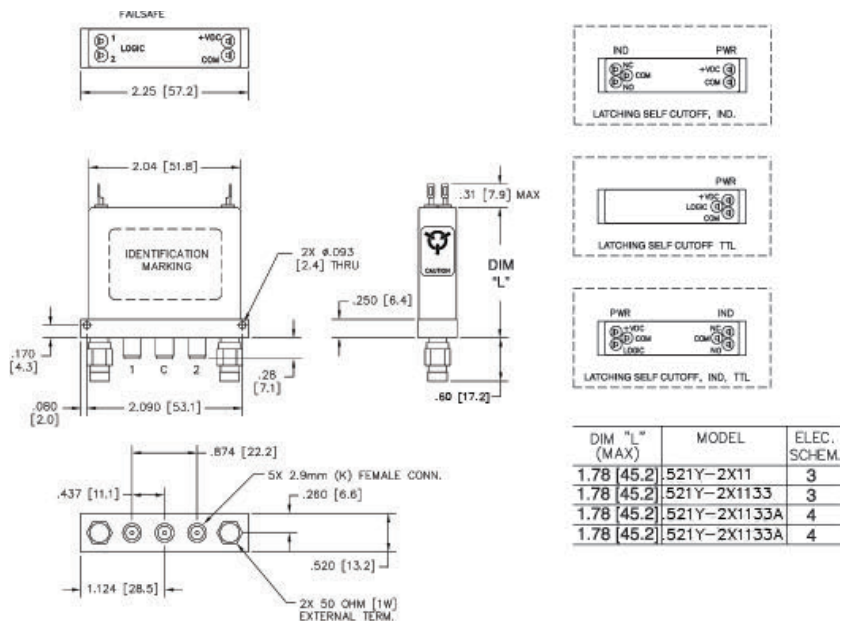

521Y-221103 shown

For Electrical Schematic, see page # 1-12

## Part Number Selector

521 J Y - 2 2 11 03 A - ROHS

Special Options	Actuator	Coil Voltage	Connectors	Indicators	Circuit Options
I = Immersion Seal	2 = Failsafe	2 = 12 Vdc	11 = 2.9 mm	02 = No Indicators, Unterminated Ports*	A = TTL High
J = 'D' Connector		3 = 28 Vdc		03 = No Indicators, 1W External Terminations	L = TTL Low
T = -55°C to +85°C		8 = 24 Vdc		32 = Indicators, Unterminated Ports	
				33 = Indicators, 1W External Terminations	

\* Declared only with Circuit Options

TTL option includes suppression diode. Other options may be available and all combinations may not be possible. Please consult with factory.



- DC-40 GHz
- Low Power
- 1M Life Cycles

## RF Characteristics

Frequency GHz	VSWR (max)	Isolation dB (min)	Ins. Loss dB (max)
DC-6	1.30	80	0.30
6-12	1.40	70	0.40
12-18	1.50	65	0.50
18-26.5	1.70	60	0.70
26.5-40	1.80	55	0.80

## Specifications

### Operating Voltage (across temperature range):

- 12 Vdc (11-14 Vdc)
- 28 Vdc (24-32 Vdc)

### Coil Current (typ. @ nom. Vdc & 25°C)\*:

- 12 Vdc 440 mA
- 24 Vdc 220 mA
- 28 Vdc 190 mA

### Switching Time:

- 20 ms maximum

### Operating Temperature:

- 25°C to +65°C (Standard)
- 55°C to +85°C (Extended "T" Option)

### Mechanical Life Cycles:

- 1,000,000 minimum

### Vibration, Operating:

- 10G RMS, 20-2000 Hz

### Mechanical Shock, Non-Operating:

- 30G, 1/2 Sine, 11 ms

### Nominal Weight\*:

- 2.5 oz. (71 g.)

\* Performance and weight varies depending on selected options.

## Mechanical

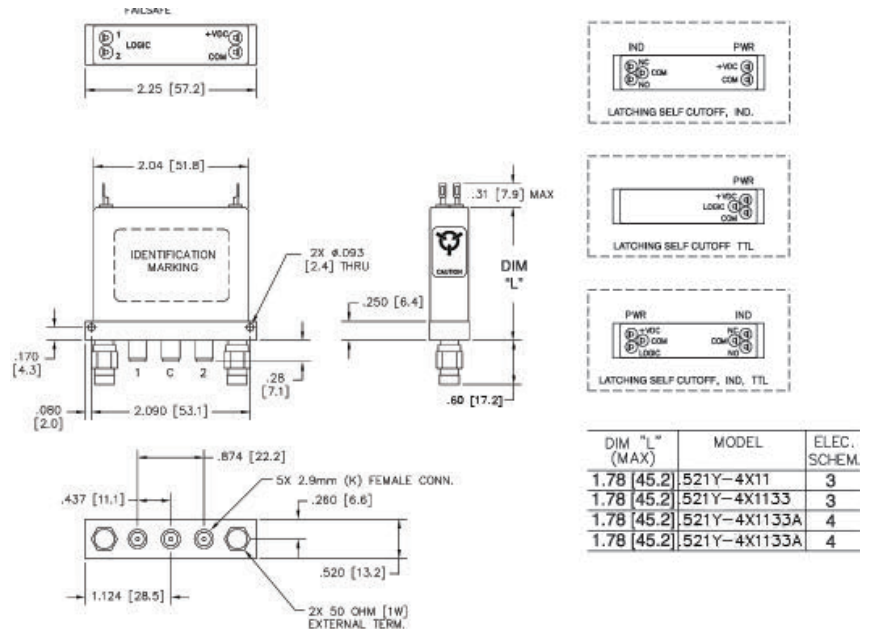

## Part Number Selector

521 J Y - 4 2 11 03 A - ROHS

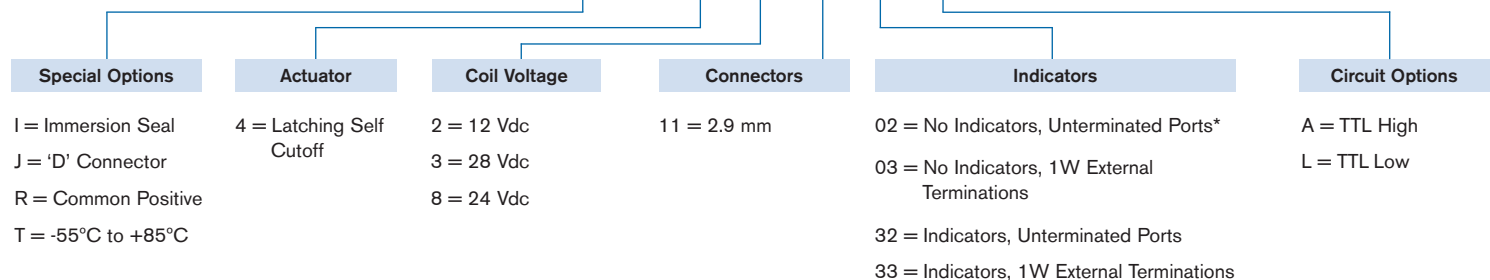

\* Declared only with Circuit Options

TTL option includes suppression diode. Other options may be available and all combinations may not be possible. Please consult with factory.

# SPDT or 2/3 521U/521Y | Electrical Schematics

01 521U/521Y Failsafe

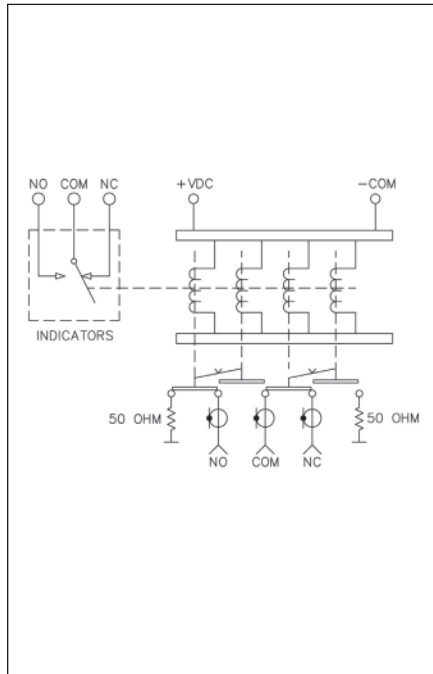

02 521U/521Y Failsafe TTL

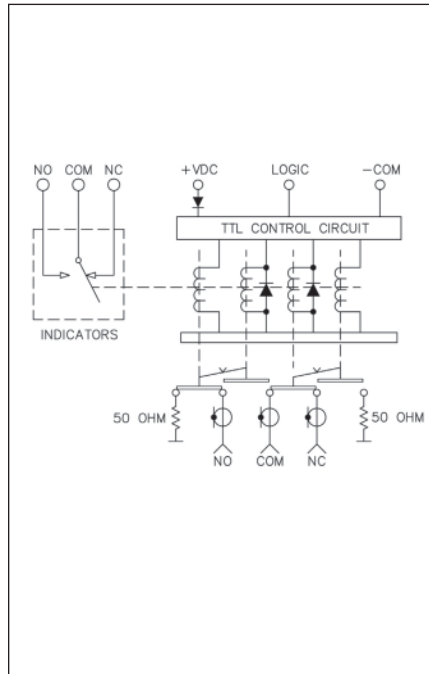

03 521U/521Y Self Cutoff

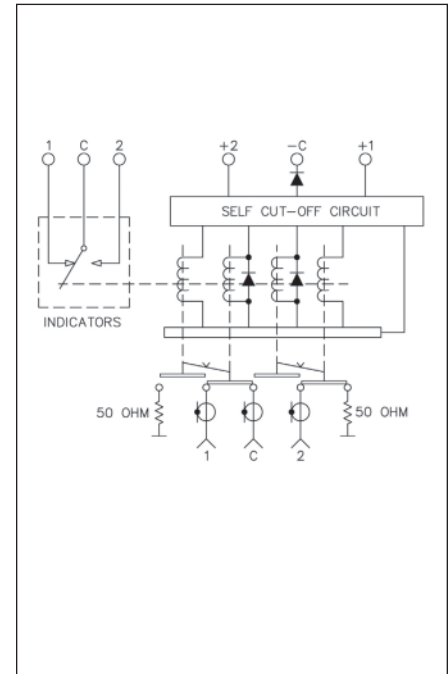

04 521U/521Y Self Cutoff TTL

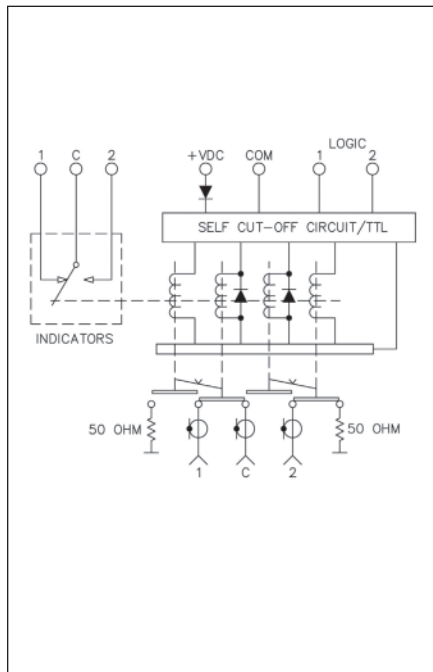

05 521U/521Y Logic Truth Table

FAILSAFE TTL - SCH #2

LOGIC TRUTH TABLE		
RF PATH	INDICATOR PATH	LOGIC INPUT
NC-COM	NC-COM	0
NO-COM	NO-COM	1

LOGIC HI (ON) 1 = 2.4-5.5Vdc  
 LOGIC LOW (OFF) 0 = 0-0.8Vdc

SELF CUTOFF TTL - SCH #4

LOGIC TRUTH TABLE		
RF PATH	LOGIC INPUT "1"	LOGIC INPUT "2"
C-1	1	0
C-2	0	1

LOGIC HI (ON) = 2.4-5.5Vdc  
 LOGIC LOW (OFF) = 0-0.8Vdc

06 521U Unterminated

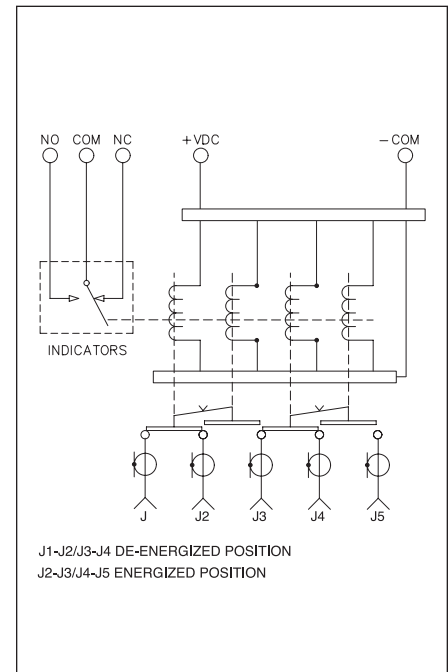

J1-J2/J3-J4 DE-ENERGIZED POSITION  
 J2-J3/J4-J5 ENERGIZED POSITION

Note: Diagram shown as Failsafe Unterminated. Consult with factory for other options.

# DPDT/TRANSFER COAXIAL SWITCH



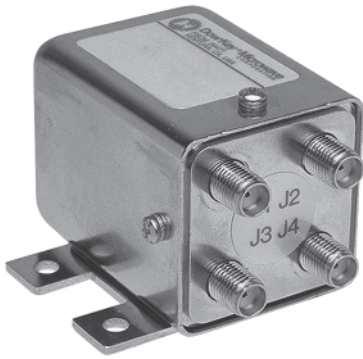

- DC-18 GHz
- DC-40 GHz
- Low/Medium Power
- 1M/5M Life Cycles

## RF Characteristics

Frequency GHz	VSWR (max)	Isolation dB (min)	Ins. Loss dB (max)
DC-1	1.10	85	0.10
1-4	1.20	80	0.20
4-8	1.30	70	0.30
8-12	1.40	65	0.40
12-18	1.50	60	0.50

For DC-40 GHz switches contact the factory

## Specifications

### Operating Voltage (across temperature range):

- 12 Vdc (11-14 Vdc)
- 24 Vdc (20-28 Vdc)
- 28 Vdc (24-32 Vdc)

### Coil Current (max. @ nom. Vdc & 25°C)\*:

- 12 Vdc 350 mA
- 24 Vdc 205 mA
- 28 Vdc 145 mA

### Switching Time:

20 ms maximum

### Operating Temperature:

- 25°C to +65°C (Standard)
- 55°C to +85°C (Extended "T" Option)

### Mechanical Life Cycles\*:

- 1,000,000 minimum
- 5,000,000 minimum ("U" Option)

### Vibration, Operating:

10G RMS, 20-2000 Hz

### Mechanical Shock, Non-Operating:

30G, 1/2 Sine, 11 ms

### Nominal Weight\*:

4.0 oz. (113 g.)

\* Performance and weight varies depending on selected options

## Mechanical

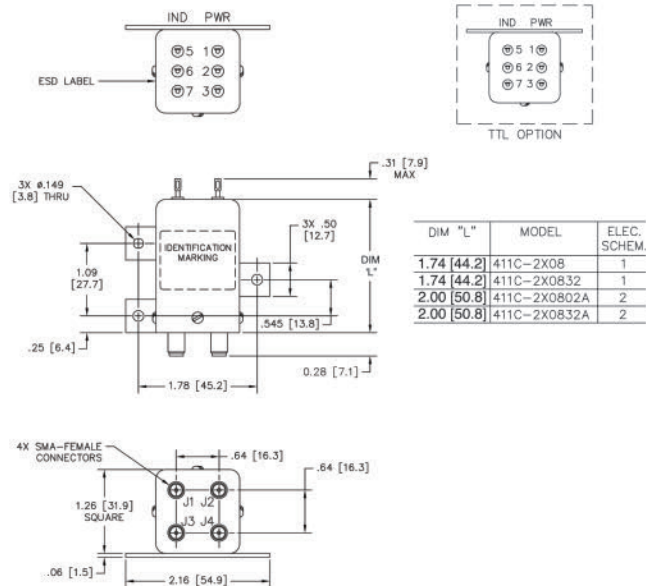

411C-2X0832A Shown

For Electrical Schematic, see page # 2-6

## Part Number Selector

411C J - 2 2 08 02 A - ROHS

Special Options	Actuator	Coil Voltage	Connectors	Indicators	Circuit Options
A = High Power	2 = Failsafe	2 = 12 Vdc	08 = SMA Female	02 = No Indicators*	A = TTL High
B = Bypass (J2-J4)	6 = Failsafe with Suppression Diode	3 = 28 Vdc	11 = 2.9 mm (K)	32 = Indicators	L = TTL Low
D = Bypass (J1-J2)		8 = 24 Vdc			
E = Bypass (J3-J4)					
F = Bypass (J1-J3)					
I = Immersion Seal					
J = 'D' Connector					
N = No Mounting Bracket					
S = Epoxy Seal					
T = -55°C to + 85°C					
U = 5M Life Cycles					
Y = 40 GHz					

\* Declared only with Circuit Options

TTL option includes suppression diode. Other options may be available and all combinations may not be possible. Please consult with factory.

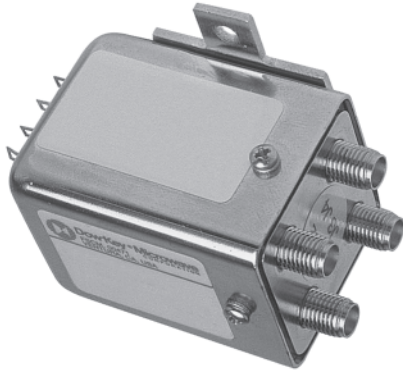

- DC-18 GHz
- DC-40 GHz
- Low/Medium Power
- 1M/5M Life Cycles

## RF Characteristics

Frequency GHz	VSWR (max)	Isolation dB (min)	Ins. Loss dB (max)
0-1	1.10	85	0.10
1-4	1.20	80	0.20
4-8	1.30	70	0.30
8-12	1.40	65	0.40
12-18	1.50	60	0.50

For DC-40 GHz switches contact the factory

## Specifications

### Operating Voltage (across temperature range):

- 12 Vdc (11-14 Vdc)
- 24 Vdc (20-28 Vdc)
- 28 Vdc (24-32 Vdc)

### Coil Current (max. @ nom. Vdc & 25°C)\*:

- 12 Vdc 320 mA
- 24 Vdc 175 mA
- 28 Vdc 135 mA

### Switching Time:

20 ms maximum

### Operating Temperature:

- 25°C to +65°C (Standard)
- 55°C to +85°C (Extended "T" Option)

### Mechanical Life, Cycles\*:

- 1,000,000 minimum
- 5,000,000 minimum ("U" Option)

### Vibration, Operating:

10G RMS, 20-2000 Hz

### Mechanical Shock, Non-Operating:

30G, 1/2 Sine, 11 ms

### Nominal Weight\*:

4.0 oz. (113 g.)

\* Performance and weight varies depending on selected options.

## Mechanical

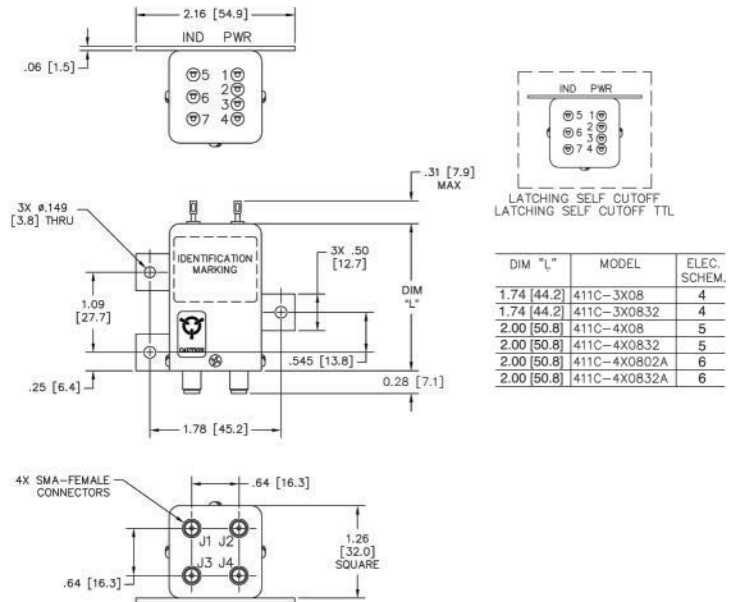

411C-4X0832A Shown

For Electrical Schematic, see page # 2-6

## Part Number Selector

**Special Options**

- A = High Power
- B = Bypass (J2-J4)
- D = Bypass (J1-J2)
- E = Bypass (J3-J4)
- F = Bypass (J1-J3)
- I = Immersion Seal
- J = 'D' Connector
- N = No Mounting Bracket
- R = (+) Com
- S = Epoxy Seal
- T = -55°C to + 85°C
- U = 5M Life Cycles
- Y = 40 GHz

**411C J - 4 2 08 02 A - ROHS**

Actuator	Coil Voltage	Connectors	Indicators	Circuit Options
3 = Pulse Latching	2 = 12 Vdc	08 = SMA Female	02 = No Indicators*	A = TTL High
4 = Latching Self Cutoff	3 = 28 Vdc	11 = 2.9 mm (K)	32 = Indicators	L = TTL Low
7 = Pulse Latching with Suppression Diode	8 = 24 Vdc			N = CANBus

\* Declared only with Circuit Options

TTL option includes suppression diode. Other options may be available and all combinations may not be possible. Please consult with factory.

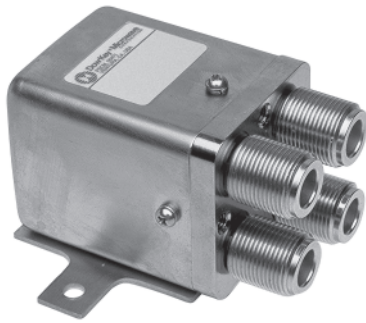

- DC-2 GHz
- DC-6 GHz
- DC-12.4 GHz
- Medium/High Power
- 1M Cycles

## RF Characteristics

Frequency GHz	VSWR (max)	Isolation dB (min)	Ins. Loss dB (max)
DC-1	1.15	85	0.15
1-2	1.20	80	0.20
2-4	1.25	70	0.25
4-8	1.45	60	0.40
8-12.4	1.60	60	0.60

Performance applies to N and TNC type connectors.  
Consult with factory for other performances.

## Specifications

### Operating Voltage (across temperature range):

- 12 Vdc (11-14 Vdc)
- 24 Vdc (20-28 Vdc)
- 28 Vdc (24-32 Vdc)

### Coil Current (max. @ nom. Vdc & 25°C)\*:

- 12 Vdc 320 mA
- 24 Vdc 200 mA
- 28 Vdc 185 mA

### Switching Time:

20 ms maximum

### Operating Temperature:

- 25°C to +65°C (Standard)
- 55°C to +85°C (Extended "T" Option)

### Mechanical Life, Cycles:

1,000,000 minimum

### Vibration, Operating:

10G RMS, 20-2000 Hz

### Mechanical Shock, Non-Operating:

30G, 1/2 Sine, 11 ms

### Nominal Weight\*:

14 oz. (397 g.)

\* Performance and weight varies depending on selected options.

## Mechanical

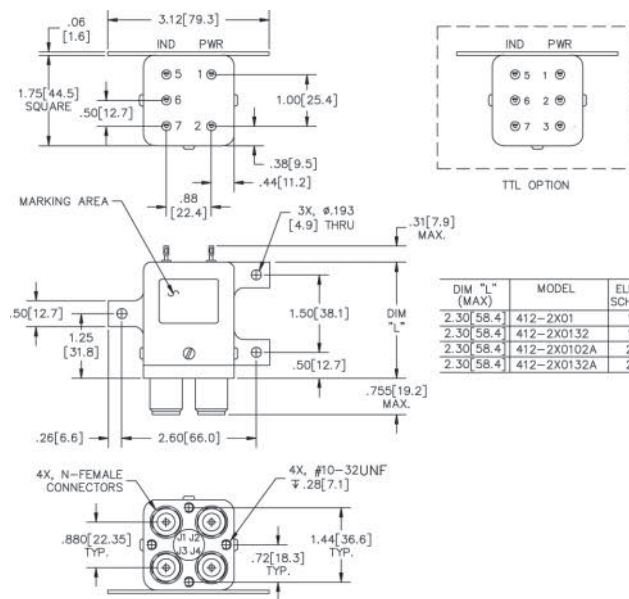

412-2X0132 Shown

For Electrical Schematic, see page # 2-6

## Part Number Selector

412 J - 2 2 01 02 A - ROHS

### Special Options

- A = High Power
- C = Special Mounting Bracket
- J = 'D' Connector
- N = No Mounting Bracket
- P = Power Plug
- S = Epoxy Seal
- T = -55°C to +85°C

### Actuator

- 2 = Failsafe
- 6 = Failsafe with Suppression Diode

### Coil Voltage

- 2 = 12 Vdc
- 3 = 28 Vdc
- 8 = 24 Vdc

### Connectors

- 01 = N Female
- 02 = BNC Female
- 03 = TNC Female
- 53 = SC Female\*

### Indicators

- 02 = No Indicators\*\*
- 32 = Indicators

\*\* Declared only with Circuit Options

### Circuit Options

- A = TTL High

\* Contact Dow-Key for dimensions

TTL option includes suppression diode. Other options may be available and all combinations may not be possible. Please consult with factory.



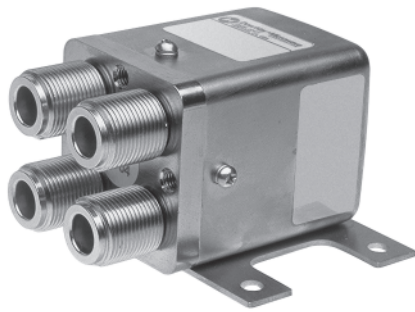

- DC-2 GHz
- DC-6 GHz
- DC-12.4 GHz
- Medium/High Power
- 1M Cycles

## RF Characteristics

Frequency GHz	VSWR (max)	Isolation dB (min)	Ins. Loss dB (max)
DC-1	1.15	85	0.15
1-2	1.20	80	0.20
2-4	1.25	70	0.25
4-8	1.45	60	0.40
8-12.4	1.60	60	0.60

Performance applies to N and TNC type connectors.  
Consult with factory for other performances.

## Specifications

### Operating Voltage (across temperature range):

- 12 Vdc (11-14 Vdc)
- 24 Vdc (20-28 Vdc)
- 28 Vdc (24-32 Vdc)

### Coil Current (max. @ nom. Vdc & 25°C)\*:

- 12 Vdc 320 mA
- 24 Vdc 240 mA
- 28 Vdc 185 mA

### Switching Time:

20 ms maximum

### Operating Temperature:

- 25°C to +65°C (Standard)
- 55°C to +85°C (Extended "T" Option)

### Mechanical Life, Cycles:

1,000,000 minimum

### Vibration, Operating:

10G RMS, 20-2000 Hz

### Mechanical Shock, Non-Operating:

30G, 1/2 Sine, 11 ms

### Nominal Weight\*:

14 oz. (397 g.)

\* Performance and weight varies depending on selected options.

## Mechanical

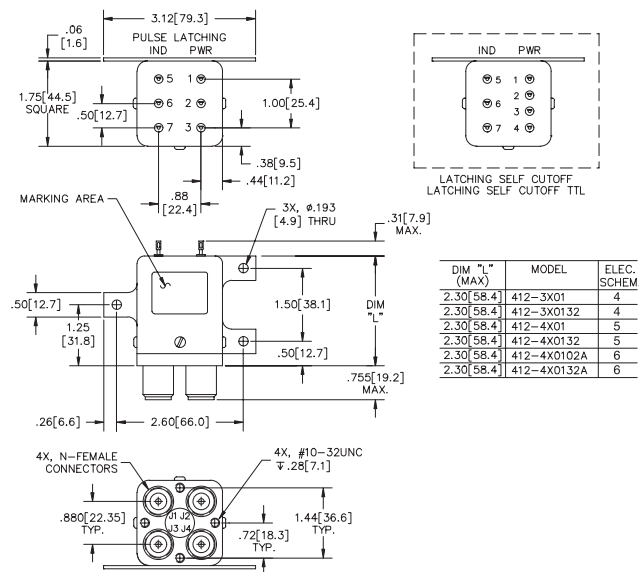

412-3X0132 Shown

For Electrical Schematic, see page # 2-6

## Part Number Selector

412 J - 4 2 01 02 A - ROHS

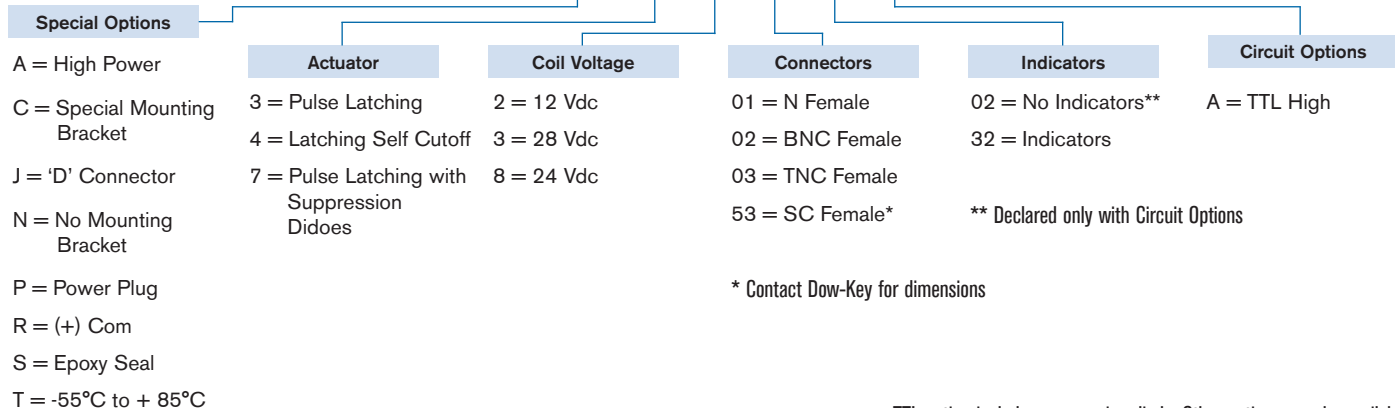

\* Contact Dow-Key for dimensions

TTL option includes suppression diode. Other options may be available and all combinations may not be possible. Please consult with factory.

### 01 411C/412 Failsafe

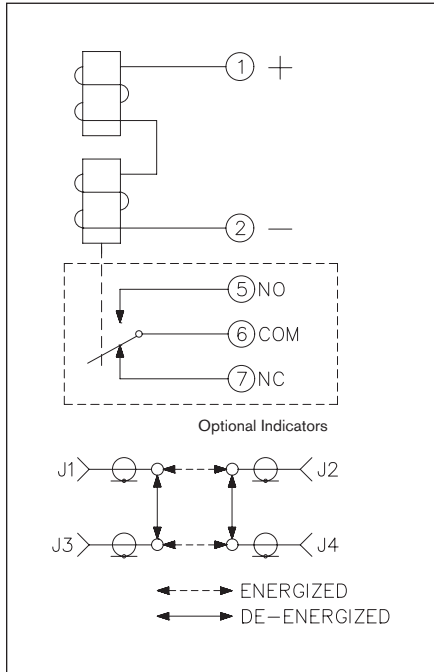

### 02 411C/412 Failsafe TTL

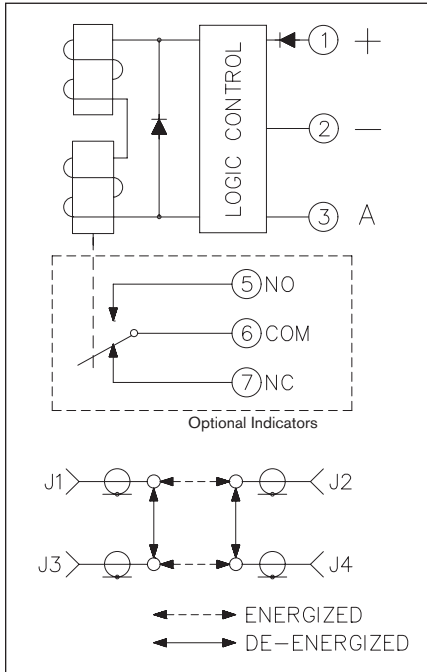

### 03 Logic Truth Table

FAILSAFE TTL - SCH #2

LOGIC TRUTH TABLE		
RF PATH	INDICATOR PATH	LOGIC INPUT "A"
J1-J3/J2-J4	NC-COM	0
J1-J2/J3-J4	NO-COM	1

"0" = 0.0V-0.8V  
 "1" = 2.4V-5.5V

SELF CUTOFF TTL - SCH #6

LOGIC TRUTH TABLE			
RF PATH	INDICATOR PATH	LOGIC INPUT "A"	LOGIC INPUT "B"
J1-J3/J2-J4	COM-1	1	0
J1-J2/J3-J4	COM-2	0	1

"0" = 0.0V-0.8V  
 "1" = 2.4V-5.5V

### 04 411C/412 Pulse

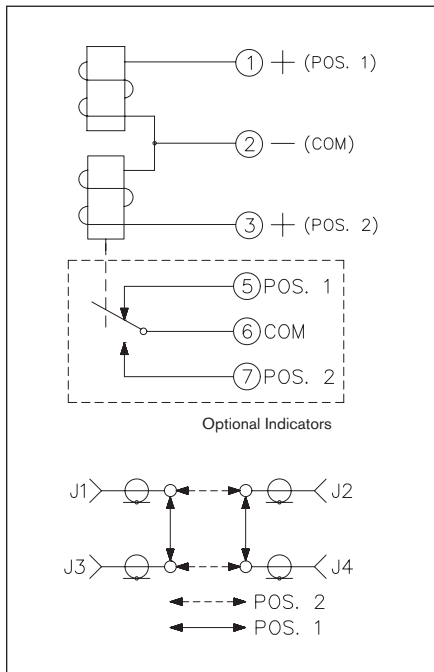

### 05 411C/412 Self Cutoff

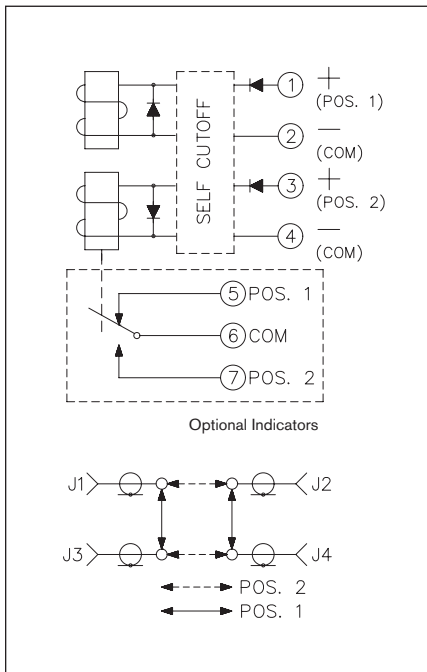

### 06 411C/412 Self Cutoff TTL

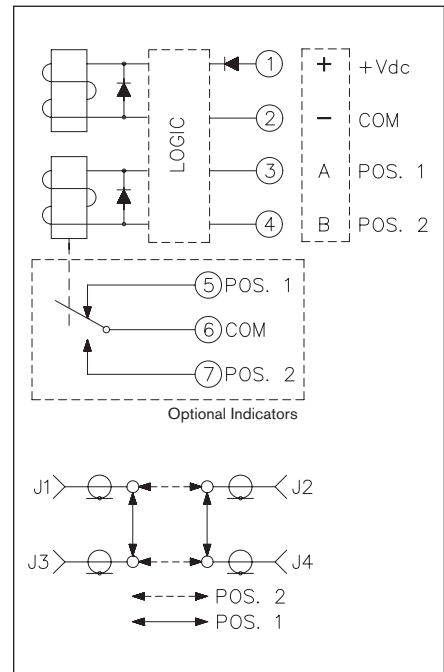

# SP3T-SP14T MULTIPOSITION COAXIAL SWITCH





- DC-18 GHz
- DC-26.5 GHz
- DC-40 GHz
- Low/Medium Power
- 1M Life Cycles

## RF Characteristics

Frequency GHz	VSWR (max)	Isolation dB (min)	Ins. Loss dB (max)
DC-4	1.20	70	0.20
4-8	1.30	65	0.30
8-12.4	1.40	65	0.40
12.4-18	1.50	60	0.50
*18-26.5	1.80	50	0.80

\* Performance varies depending on selected options

For DC-40 GHz switches contact the factory

## Specifications

### Operating Voltage:

- 12 Vdc (11-14 Vdc)
- 24 Vdc (20-28 Vdc)
- 28 Vdc (24-32 Vdc)

### Coil Current (max. @ nom. Vdc & 25°C)\*:

- 12 Vdc 335 mA
- 24 Vdc 190 mA
- 28 Vdc 160 mA

### Switching Time:

20 ms maximum

### Operating Temperature:

- 25°C to +65°C (Standard)
- 55°C to +85°C (Extended "T" Option)

### Mechanical Life Cycles:

1,000,000 minimum

### Vibration, Operating:

10G RMS, 20-2000 Hz

### Mechanical Shock, Non-Operating:

30G, 1/2 Sine, 11 ms

### Nominal Weight\*:

4.0 oz. (113 g.)

\* Performance and weight varies depending on selected options.

## Mechanical

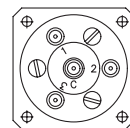
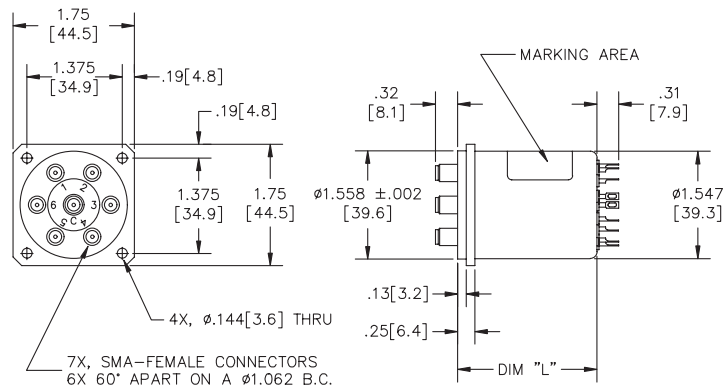

3 POSITION

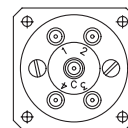

4 POSITION

DIM "L" (MAX)	MODEL	ELEC. SCHEM.
1.41 [35.8]	5X5-5X08	1
1.90 [48.3]	5X5-5X0822	1
1.70 [43.2]	5X5-5X0802A	2
2.10 [53.3]	5X5-5X0822A	2

565-530822 Shown

For Electrical Schematic, see page # 3-20

## Part Number Selector

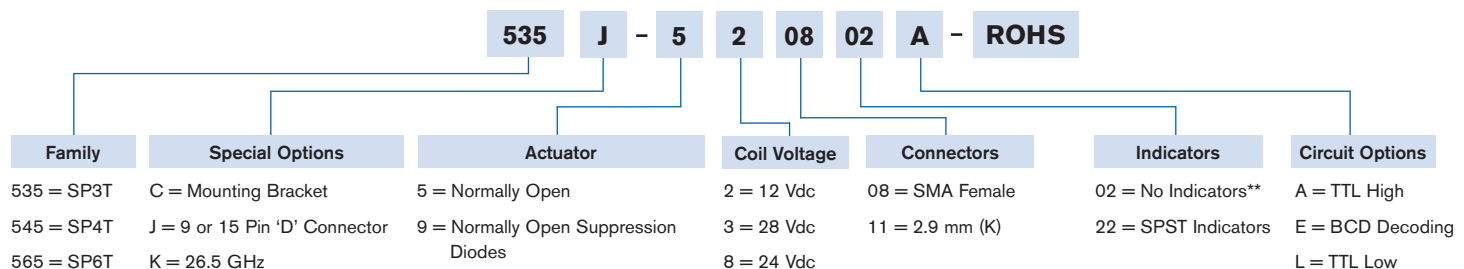

\*\* Declared only with Circuit Options

TTL option includes suppression diode. Other options may be available and all combinations may not be possible. Please consult with factory.



- DC-18 GHz
- DC-26.5 GHz
- Low/Medium Power
- 1M Life Cycles

## RF Characteristics

Frequency GHz	VSWR (max)	Isolation dB (min)	Ins. Loss dB (max)
DC-4	1.20	80	0.20
4-8	1.30	70	0.30
8-12.4	1.40	65	0.40
12.4-18	1.50	60	0.50
*18-26.5	1.80	55	0.80

\* Performance varies depending on selected options

## Specifications

### Operating Voltage:

- 12 Vdc (11-14 Vdc)
- 24 Vdc (20-28 Vdc)
- 28 Vdc (24-32 Vdc)

### Coil Current (max. @ nom. Vdc & 25°C)\*:

- 12 Vdc 345 mA
- 24 Vdc 200 mA
- 28 Vdc 160 mA

### Switching Time:

15 ms maximum

### Operating Temperature:

- 25°C to +65°C (Standard)
- 55°C to +85°C (Extended "T" Option)

### Mechanical Life, Cycles:

1,000,000 minimum

### Vibration, Operating:

10G RMS, 20-2000 Hz

### Mechanical Shock, Non-Operating:

30G, 1/2 Sine, 11 ms

### Nominal Weight\*:

10.0 oz. (284 g.)

\* Performance and weight varies depending on selected options.

## Mechanical

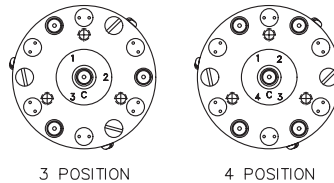
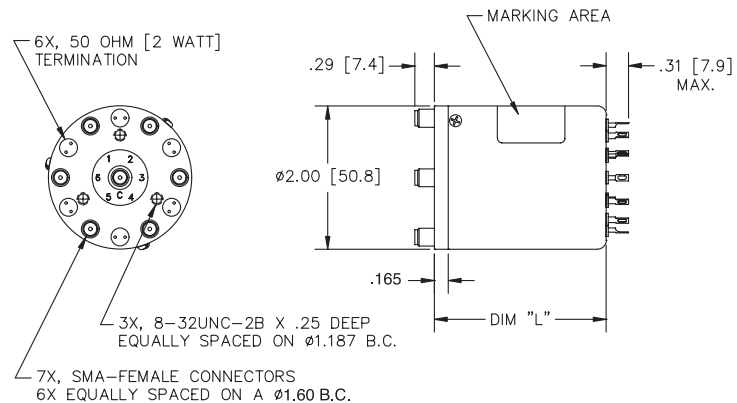

DIM "L" (MAX)	MODEL	ELEC. SCHEM.
2.70 [68.6]	4X1-5X0803	3
2.70 [68.6]	4X1-5X0823	3
2.70 [68.6]	4X1-5X0803A	4
3.00 [76.2]	4X1-5X0823A	4

461-530823 Shown

For Electrical Schematic, see page # 3-20

## Part Number Selector

431 J - 5 2 08 03 A - ROHS

Family	Special Options	Actuator	Coil Voltage	Connectors	Indicators	Circuit Options
431 = SP3T	C = Mounting Bracket	5 = Normally Open	2 = 12 Vdc	08 = SMA Female	03 = No Indicators	A = TTL High
441 = SP4T	J = 9 or 15 Pin 'D' Connector	9 = Normally Open Suppression Diodes	3 = 28 Vdc		2W Terminations	L = TTL Low
461 = SP6T	K = 26.5 GHz		8 = 24 Vdc		23 = SPST Indicators	
	L = Flange Mount				2W Terminations	
	P = Power Plug					
	R = (-) Com*					
	S = Epoxy Seal					
	T = -55° to +85° C					

\* Only available with Normally Open Suppression Diodes

TTL option includes suppression diode. Other options may be available and all combinations may not be possible. Please consult with factory.



- DC-18 GHz
- DC-26.5 GHz
- Low/Medium Power
- 1M Life Cycles

## RF Characteristics

Frequency GHz	VSWR (max)	Isolation dB (min)	Ins. Loss dB (max)
DC-4	1.20	80	0.20
4-8	1.30	75	0.30
8-12.4	1.40	70	0.40
12.4-18	1.50	60	0.50
*18-26.5	1.80	55	0.80

\* Performance varies depending on selected options

## Specifications

### Operating Voltage:

- 12 Vdc (11-14 Vdc)
- 24 Vdc (20-28 Vdc)
- 28 Vdc (24-32 Vdc)

### Coil Current (max. @ nom. Vdc & 25°C)\*:

- 12 Vdc 570 mA
- 24 Vdc 225 mA
- 28 Vdc 180 mA

### Switching Time:

15 ms maximum

### Operating Temperature:

- 25°C to +65°C (Standard)
- 55°C to +85°C (Extended "T" Option)

### Mechanical Life Cycles:

1,000,000 minimum

### Vibration, Operating:

10G RMS, 20-2000 Hz

### Mechanical Shock, Non-Operating:

30G, 1/2 Sine, 11 ms

### Nominal Weight\*:

11.0 oz. (312 g.)

\* Performance and weight varies depending on selected options.

## Mechanical

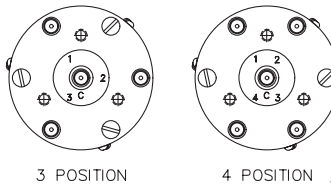
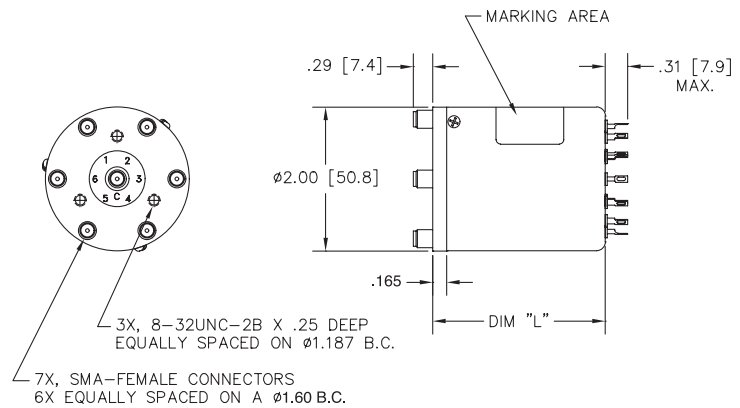

DIM "L" (MAX)	MODEL	ELEC. SCHEM.
2.40 [61.0]	4X1-4X08	1
2.70 [68.6]	4X1-4X0822	1
3.00 [76.2]	4X1-4X0802A	2
3.00 [76.2]	4X1-4X0822A	2

461-430822 Shown

For Electrical Schematic, see page # 3-21

## Part Number Selector

461 J - 4 2 08 02 A - ROHS

Family	Special Options	Actuator	Coil Voltage	Connectors	Indicators	Circuit Options
431 = SP3T	C = Mounting Bracket	4 = Latching Self Cutoff	2 = 12 Vdc	08 = SMA Female	02 = No Indicators*	A = TTL High
441 = SP4T	J = 9 or 15 Pin 'D' Connector		3 = 28 Vdc		22 = SPST Indicators	N = CANBus
461 = SP6T	K = 26.5 GHz		8 = 24 Vdc			
	L = Flange Mount					
	P = Power Plug					
	R = (-) Com					
	S = Epoxy Seal					
	T = -55° to +85° C					

\*\* Declared only with Circuit Options

TTL option includes suppression diode. Other options may be available and all combinations may not be possible. Please consult with factory.



- DC-18 GHz
- DC-26.5 GHz
- Low/Medium Power
- 1M Life Cycles

## RF Characteristics

Frequency GHz	VSWR (max)	Isolation dB (min)	Ins. Loss dB (max)
DC-4	1.20	80	0.20
4-8	1.30	75	0.30
8-12.4	1.40	70	0.40
12.4-18	1.50	60	0.50
*18-26.5	1.80	50	0.80

\*Performance varies depending on selected options

## Specifications

### Operating Voltage:

- 12 Vdc (11-14 Vdc)
- 24 Vdc (20-28 Vdc)
- 28 Vdc (24-32 Vdc)

### Coil Current (max. @ nom. Vdc & 25°C)\*:

- 12 Vdc 570 mA
- 24 Vdc 225 mA
- 28 Vdc 180 mA

### Switching Time:

15 ms maximum

### Operating Temperature:

- 25°C to +65°C (Standard)
- 55°C to +85°C (Extended "T" Option)

### Mechanical Life, Cycles:

1,000,000 minimum

### Vibration, Operating:

10G RMS, 20-2000 Hz

### Mechanical Shock, Non-Operating:

30G, 1/2 Sine, 11 ms

### Nominal Weight\*:

11.0 oz. (312 g.)

\* Performance and weight varies depending on selected options.

## Mechanical

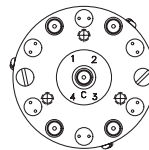
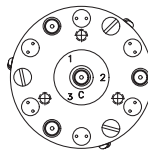
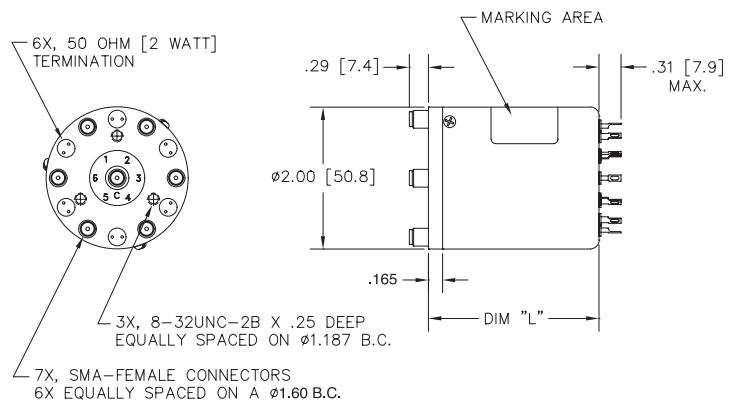

DIM "L" (MAX)	MODEL	ELEC. SCHEM.
2.40 [61.0]	4X1-4X0803	3
2.70 [68.6]	4X1-4X0823	3
3.00 [76.2]	4X1-4X0803A	4
3.00 [76.2]	4X1-4X0823A	4

461-430823 Shown

For Electrical Schematic, see page # 3-21

## Part Number Selector

461 J - 4 2 08 03 A - ROHS

Family	Special Options	Actuator	Coil Voltage	Connectors	Indicators	Circuit Options
431 = SP3T	C = Mounting Bracket	4 = Latching Self Cutoff	2 = 12 Vdc	08 = SMA Female	03 = No Indicators	A = TTL High
441 = SP4T	J = 9 or 15 Pin 'D' Connector		3 = 28 Vdc		2W Terminations	N = CANBus
461 = SP6T	L = Flange Mount		8 = 24 Vdc		23 = SPST Indicators	
	K = 26.5 GHz				2W Terminations	
	P = Power Plug					
	R = (-) Com					
	S = Epoxy Seal					
	T = -55° to +85° C					

TTL option includes suppression diode. Other options may be available and all combinations may not be possible. Please consult with factory.

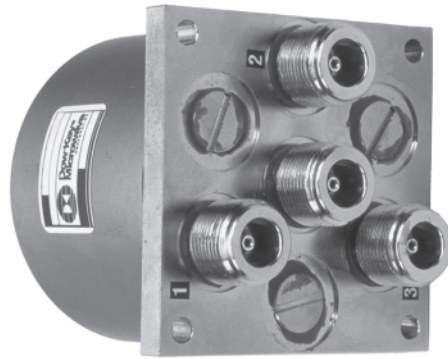

- DC-2 GHz
- DC-6 GHz
- DC-12.4 GHz
- Medium/High Power
- 1M Life Cycles

## RF Characteristics

Frequency GHz	VSWR (max)	Isolation dB (min)	Ins. Loss dB (max)
DC-4	1.25	70	0.30
4-8	1.45	60	0.40
8-12.4	1.70	55	0.70

Performance varies depending on selected options

## Specifications

### Operating Voltage:

- 12 Vdc (11-14 Vdc)
- 24 Vdc (20-28 Vdc)
- 28 Vdc (24-32 Vdc)

### Coil Current (max. @ nom. Vdc & 25°C)\*:

- 12 Vdc 105 mA
- 24 Vdc 70 mA
- 28 Vdc 60 mA

### Switching Time:

20 ms maximum

### Operating Temperature:

- 25°C to +65°C (Standard)
- 55°C to +85°C (Extended "T" Option)

### Mechanical Life Cycles:

1,000,000 minimum

### Vibration, Operating:

10G RMS, 20-2000 Hz

### Mechanical Shock, Non-Operating:

30G, 1/2 Sine, 11 ms

### Nominal Weight\*:

17.0 oz. (482 g.)

\* Performance and weight varies depending on selected options.

## Mechanical

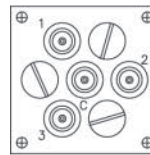
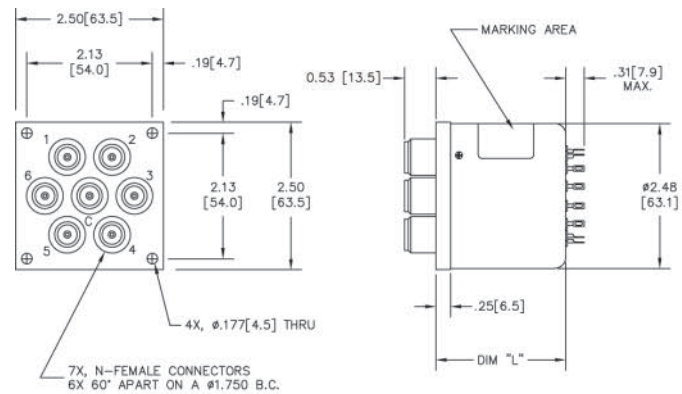

3 POSITION

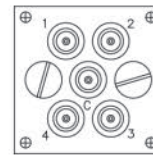

4 POSITION

DIM "L" (MAX)	MODEL	ELEC. SCHEM.
2.20 [55.9]	5X1-5X01	1
2.62 [66.5]	5X1-5X0122	1
2.90 [73.7]	5X1-5X0102A	2
2.90 [73.7]	5X1-5X0122A	2

561-530122 Shown

For Electrical Schematic, see page # 3-20

## Part Number Selector

561 J - 5 2 01 02 A - ROHS

Family	Special Options	Actuator	Coil Voltage	Connectors	Indicators	Circuit Options
531 = SP3T	A = High Power	5 = Normally Open	2 = 12 Vdc	01 = N Female	02 = No Indicators*	A = TTL High
541 = SP4T	C = Mounting Bracket	9 = Normally Open Suppression Diodes	3 = 28 Vdc	02 = BNC Female	22 = SPST Indicators	
561 = SP6T	J = 9 or 15 Pin 'D' Connector		8 = 24 Vdc	03 = TNC Female		
	S = Epoxy Seal			53 = SC Female		** Declared only with Circuit Options
	T = -55° to +85° C					

TTL option includes suppression diode. Other options may be available and all combinations may not be possible. Please consult with factory.





- DC-2 GHz
- DC-6 GHz
- DC-12.4 GHz
- Medium/High Power
- 1M Life Cycles

## RF Characteristics

Frequency GHz	VSWR (max)	Isolation dB (min)	Ins. Loss dB (max)
DC-4	1.25	70	0.30
4-8	1.45	60	0.40
8-12.4	1.70	55	0.70

Performance applies to N and TNC type connectors.  
Consult with factory for other performances.

## Specifications

### Operating Voltage:

- 12 Vdc (11-14 Vdc)
- 24 Vdc (20-28 Vdc)
- 28 Vdc (24-32 Vdc)

### Coil Current (max. @ nom. Vdc & 25°C)\*:

- 12 Vdc 550 mA
- 24 Vdc 275 mA
- 28 Vdc 240 mA

### Switching Time:

20 ms maximum

### Operating Temperature:

- 25°C to +65°C (Standard)
- 55°C to +85°C (Extended "T" Option)

### Mechanical Life, Cycles:

1,000,000 minimum

### Vibration, Operating:

10G RMS, 20-2000 Hz

### Mechanical Shock, Non-Operating:

30G, 1/2 Sine, 11 ms

### Nominal Weight\*:

22.0 oz. (624 g.)

\* Performance and weight varies depending on selected options.

## Mechanical

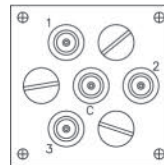
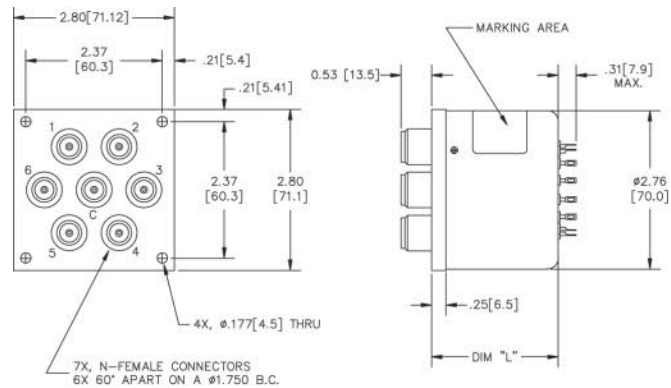

3 POSITION

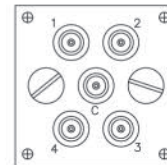

4 POSITION

DIM "L" (MAX)	MODEL	ELEC. SCHEM.
2.20 [55.9]	5X1-4X01	1
2.95 [74.9]	5X1-4X0122	1
2.95 [74.9]	5X1-4X0102A	2
2.95 [74.9]	5X1-4X0122A	2

561-430122A Shown

For Electrical Schematic, see page # 3-21

## Part Number Selector

**561 J - 4 2 01 02 A - ROHS**

Family	Special Options	Actuator	Coil Voltage	Connectors	Indicators	Circuit Options
531 = SP3T	A = High Power	4 = Latching Self Cutoff	2 = 12 Vdc	01 = N Female	02 = No Indicators*	A = TTL High
541 = SP4T	C = Mounting Bracket		3 = 28 Vdc	02 = BNC Female	22 = SPST Indicators	
561 = SP6T	J = 9 or 15 Pin 'D' Connector		8 = 24 Vdc	03 = TNC Female		
	P = Power Plug			53 = SC Female	** Declared only with Circuit Options	
	R = (-) Com					
	S = Epoxy Seal					
	T = -55° to +85° C					

TTL option includes suppression diode. Other options may be available and all combinations may not be possible. Please consult with factory.



461Y-4X11 Shown

- DC-40 GHz
- Medium/High Power
- 1M Life Cycles

## RF Characteristics

Frequency GHz	VSWR (max)	Isolation dB (min)	Ins. Loss dB (max)
DC-6	1.30	70	0.30
6-12	1.40	60	0.40
12-18	1.50	60	0.50
18-26.5	1.70	55	0.70
26.5-40	1.95	50	0.95

## Specifications

### Operating Voltage (across temperature range):

- 12 Vdc (11-14 Vdc)
- 24 Vdc (20-28 Vdc)
- 28 Vdc (24-32 Vdc)

### Coil Current (max. @ nom. Vdc & 25°C)\*:

- 12 Vdc 565 mA
- 24 Vdc 255 mA
- 28 Vdc 220 mA

### Switching Time:

15 ms maximum

### Operating Temperature:

- 25°C to +65°C (Standard)
- 55°C to +85°C (Extended "T" Option)

### Mechanical Life, Cycles:

1,000,000 minimum

### Vibration, Operating:

10G RMS, 20-2000 Hz

### Mechanical Shock, Non-Operating:

30G, 1/2 Sine, 11 ms

### Nominal Weight:

11.0 oz. (312 g.)

\* Performance and weight varies depending on selected options.

## Mechanical

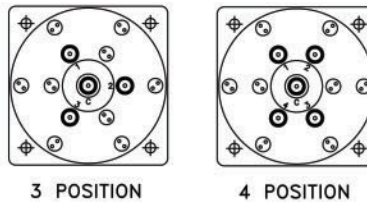
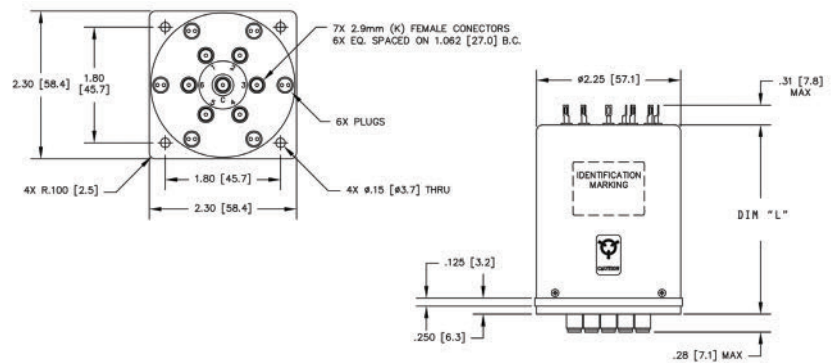

DIM "L" (MAX)	MODEL	ELEC. SCHEM.
3.10 [78.7]	5X1Y-4X11	3
3.10 [78.7]	5X1Y-4X22	3
3.10 [78.7]	5X1Y-4X1102A	4
3.10 [78.7]	5X1Y-4X1122A	4

561Y-4311 Shown

For Electrical Schematic, see page # 3-21

## Part Number Selector

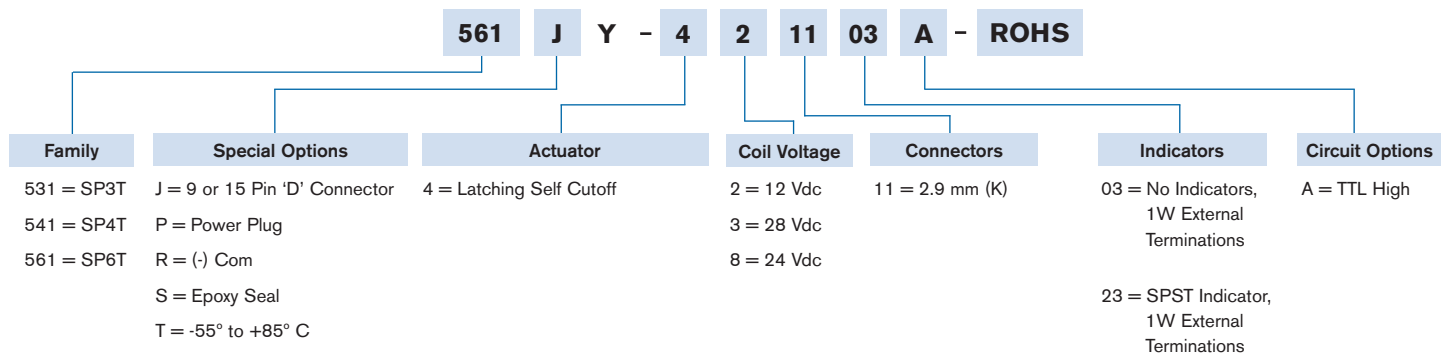

TTL option includes suppression diode. Other options may be available and all combinations may not be possible. Please consult with factory.



- DC-18 GHz
- Low/Medium Power
- 1M Life Cycles

## RF Characteristics

Frequency GHz	VSWR (max)	Isolation dB (min)	Ins. Loss dB (max)
DC-4	1.20	75	0.20
4-8	1.30	65	0.30
8-12.4	1.40	60	0.40
12.4-18	1.60	60	0.60

Performance varies depending on selected options

## Specifications

### Operating Voltage (across temperature range):

- 12 Vdc (11-14 Vdc)
- 24 Vdc (20-28 Vdc)
- 28 Vdc (24-32 Vdc)

### Coil Current (max. @ nom. Vdc & 25°C)\*:

- 12 Vdc 300 mA
- 24 Vdc 150 mA
- 28 Vdc 130 mA

### Switching Time:

15 ms maximum

### Operating Temperature:

- 25°C to +65°C (Standard)
- 55°C to +85°C (Extended "T" Option)

### Mechanical Life Cycles:

1,000,000 minimum

### Vibration, Operating:

10G RMS, 20-2000 Hz

### Mechanical Shock, Non-Operating:

30G, 1/2 Sine, 11 ms

### Nominal Weight\*:

5.0 oz. (142 g.)

\* Performance and weight varies depending on selected options.

## Mechanical

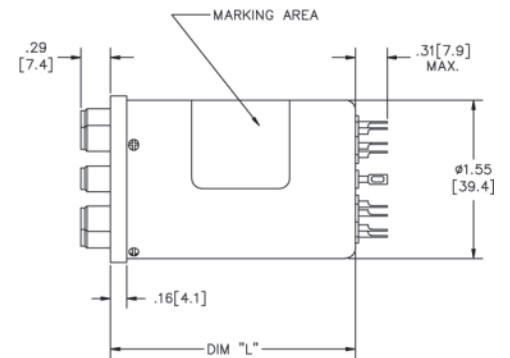
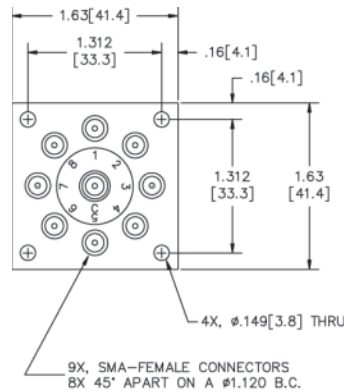

DIM "L" (MAX)	MODEL	ELEC. SCHEM.
1.60 [40.6]	5Y1-5X08	1
2.04 [51.8]	5Y1-5X0822	1
1.91 [48.5]	5Y1-5X0802A	2
2.58 [65.5]	5Y1-5X0822A	2

581-530822 Shown

For Electrical Schematic, see page # 3-20

## Part Number Selector

581 J - 5 2 08 02 A - ROHS

Special Options	Actuator	Coil Voltage	Connectors	Indicators	Circuit Options
C = Mounting Bracket	5 = Normally Open	2 = 12 Vdc	08 = SMA Female	02 = No Indicators*	A = TTL High
J = 9 or 26 Pin 'D' Connector	9 = Normally Open Suppression Diodes	3 = 28 Vdc		22 = SPST Indicators	N = CANBus
S = Epoxy Seal		8 = 24 Vdc			
T = -55° to +85° C					

\* Declared only with Circuit Options

TTL option includes suppression diode. Other options may be available and all combinations may not be possible. Please consult with factory.



- DC-18 GHz
- DC-26.5 GHz
- Low/Medium Power
- 1M Life Cycles

## RF Characteristics

Frequency GHz	VSWR (max)	Isolation dB (min)	Ins. Loss dB (max)
DC-4	1.20	80	0.20
4-8	1.30	75	0.30
8-12.4	1.40	70	0.40
12.4-18	1.50	60	0.50
18-26.5	1.80	55	0.80

Performance may vary depending on selected options

## Specifications

### Operating Voltage:

- 12 Vdc (11-14 Vdc)
- 24 Vdc (20-28 Vdc)
- 28 Vdc (24-32 Vdc)

### Coil Current (max. @ nom. Vdc & 25°C)\*:

- 12 Vdc 345 mA
- 24 Vdc 175 mA
- 28 Vdc 150 mA

### Switching Time:

15 ms maximum

### Operating Temperature:

- 25°C to +65°C (Standard)
- 55°C to +85°C (Extended "T" Option)

### Mechanical Life, Cycles:

1,000,000 minimum

### Vibration, Operating:

10G RMS, 20-2000 Hz

### Mechanical Shock, Non-Operating:

30G, 1/2 Sine, 11 ms

### Nominal Weight:

16.5 oz. (468 g.)

\* Performance and weight varies depending on selected options.

## Mechanical

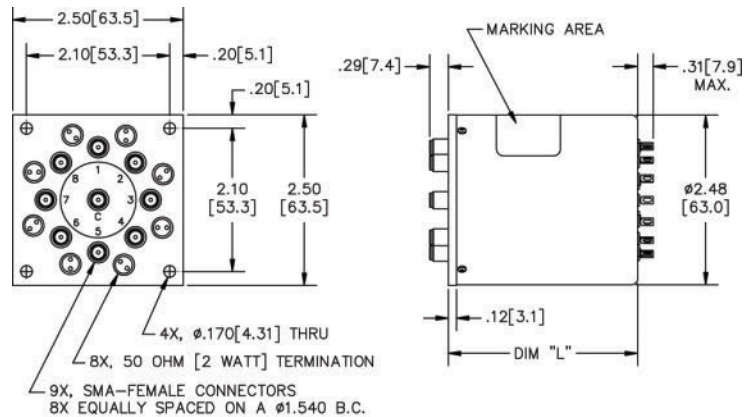

DIM "L" (MAX)	MODEL	ELEC. SCHEM.
2.00 [50.8]	5X1-5X0803	3
2.25 [57.2]	5X1-5X0823	3
2.80 [71.1]	5X1-5X0803A	4
2.80 [71.1]	5X1-5X0823A	4

581-530823 Shown

For Electrical Schematic, see page # 3-20

## Part Number Selector

581 J - 5 2 08 03 A - ROHS

### Special Options

- J = 9 or 26 Pin 'D' Connector
- K = 26.5 GHz
- P = Power Plug
- R = (-) Com
- S = Epoxy Seal
- T = -55° to +85° C

### Actuator

- 5 = Normally Open
- 9 = Normally Open Suppression Diodes

### Coil Voltage

- 2 = 12 Vdc
- 3 = 28 Vdc
- 8 = 24 Vdc

### Connectors

- 08 = SMA Female

### Indicators

- 03 = No Indicators 2W Terminations
- 23 = SPST Indicators 2W Terminations

### Circuit Options

- A = TTL High
- E = BCD Decoding

TTL option includes suppression diode. Other options may be available and all combinations may not be possible. Please consult with factory.



- DC-18 GHz
- Low/Medium Power
- 1M Life Cycles

## RF Characteristics

Frequency GHz	VSWR (max)	Isolation dB (min)	Ins. Loss dB (max)
DC-4	1.20	80	0.20
4-8	1.30	75	0.30
8-12.4	1.40	70	0.40
12.4-18	1.50	60	0.50

Performance may vary depending on selected options

## Specifications

### Operating Voltage:

- 12 Vdc (11-14 Vdc)
- 24 Vdc (20-28 Vdc)
- 28 Vdc (24-32 Vdc)

### Coil Current (max. @ nom. Vdc & 25°C)\*:

- 12 Vdc 440 mA
- 24 Vdc 225 mA
- 28 Vdc 190 mA

### Switching Time:

- 15 ms maximum

### Operating Temperature:

- 25°C to +65°C (Standard)
- 55°C to +85°C (Extended "T" Option)

### Mechanical Life, Cycles:

- 1,000,000 minimum

### Vibration, Operating:

- 10G RMS, 20-2000 Hz

### Mechanical Shock, Non-Operating:

- 30G, 1/2 Sine, 11 ms

### Nominal Weight\*:

- 18.0 oz. (510 g.)

\* Performance and weight varies depending on selected options.

## Mechanical

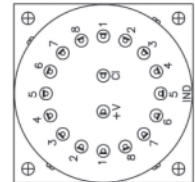
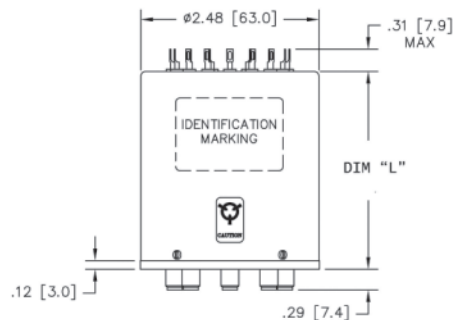
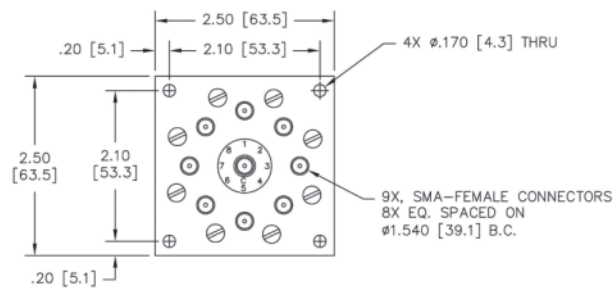

DIM "L" (MAX)	MODEL	ELEC. SCHEM.
2.40 [61.0]	5Y1-4X08	1
2.80 [71.1]	5Y1-4X0822	1
2.80 [71.1]	5Y1-4X0102A	2
2.80 [71.1]	5Y1-4X01022A	2

581-430822 Shown

For Electrical Schematic, see page # 3-21

## Part Number Selector

581 J - 4 2 08 02 A - ROHS

Special Options	Actuator	Coil Voltage	Connectors	Indicators	Circuit Options
J = 9 or 26 Pin 'D' Connector P = Power Plug R = (-) Com S = Epoxy Seal T = -55° to +85° C	4 = Latching Self Cutoff	2 = 12 Vdc 3 = 28 Vdc 8 = 24 Vdc	08 = SMA Female	02 = No Indicators* 22 = SPST Indicators	A = TTL High

\* Declared only with Circuit Options

Note: TTL option includes suppression diode. Other options may be available and all combinations may not be possible. Please consult with factory.

## RF Characteristics

- DC-18 GHz
- DC-26.5 GHz
- Low/Medium Power
- 1M Life Cycles

Frequency GHz	VSWR (max)	Isolation dB (min)	Ins. Loss dB (max)
DC-4	1.20	80	0.20
4-8	1.30	75	0.30
8-12.4	1.40	70	0.40
12.4-18	1.50	60	0.50
18-26.5	1.70	55	0.70

Performance may vary depending on selected options

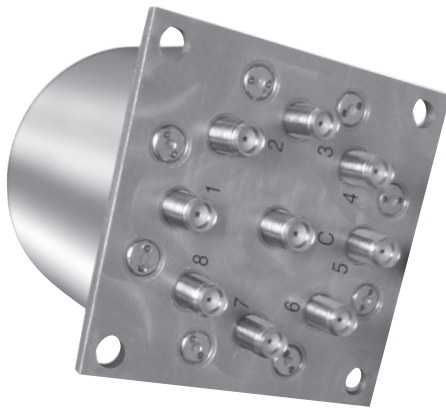

## Specifications

### Operating Voltage:

- 12 Vdc (11-14 Vdc)
- 24 Vdc (20-28 Vdc)
- 28 Vdc (24-32 Vdc)

### Coil Current (max. @ nom. Vdc & 25°C)\*:

- 12 Vdc 440 mA
- 24 Vdc 225 mA
- 28 Vdc 190 mA

### Switching Time:

- 15 ms maximum

### Operating Temperature:

- 25°C to +65°C (Standard)
- 55°C to +85°C (Extended "T" Option)

### Mechanical Life, Cycles:

- 1,000,000 minimum

### Vibration, Operating:

- 10G RMS, 20-2000 Hz

### Mechanical Shock, Non-Operating:

- 50G, 1/2 Sine, 11 ms

### Nominal Weight:

- 18.0 oz. (510 g.)

\* Performance and weight varies depending on selected options.

## Mechanical

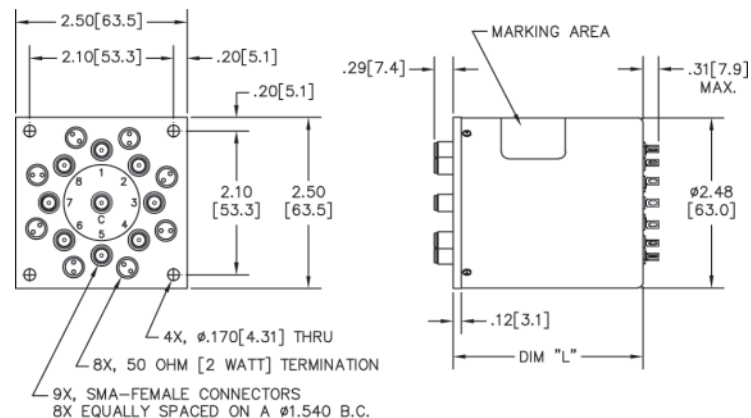

DIM "L" (MAX)	MODEL	ELEC. SCHEM.
2.40 [61.0]	5Y1-4X0803	3
2.80 [71.1]	5Y1-4X0823	3
2.80 [71.1]	5Y1-4X0803A	4
2.80 [71.1]	5Y1-4X0823A	4

581-430823 Shown

For Electrical Schematic, see page # 3-21

## Part Number Selector

581 J - 4 2 08 03 A - ROHS

Special Options	Actuator	Coil Voltage	Connectors	Indicators	Circuit Options
J = 9 or 26 Pin 'D' Connector	4 = Latching Self Cutoff	2 = 12 Vdc	08 = SMA Female	03 = No Indicators 2W Terminations	A = TTL High N = CANBus
K = 26.5 GHz		3 = 28 Vdc		23 = SPST Indicators 2W Terminations	
P = Power Plug		8 = 24 Vdc		53 = Indicators 2W Terminations*	
R = (-) Com					
S = Epoxy Seal					
T = -55° to +85° C					

\* Only used with CANBus Option

TTL option includes suppression diode. Other options may be available and all combinations may not be possible. Please consult with factory.



- DC-18 GHz
- Low/Medium Power
- 1M Life Cycles

## RF Characteristics

Frequency GHz	VSWR (max)	Isolation dB (min)	Ins. Loss dB (max)
DC-4	1.20	70	0.20
4-8	1.30	65	0.30
8-12.4	1.40	60	0.40
12.4-18	1.60	55	0.60

Performance may vary depending on selected options

## Specifications

### Operating Voltage:

- 12 Vdc (11-14 Vdc)
- 24 Vdc (20-28 Vdc)
- 28 Vdc (24-32 Vdc)

### Coil Current (max. @ nom. Vdc & 25°C)\*:

- 12 Vdc 300 mA
- 24 Vdc 150 mA
- 28 Vdc 135 mA

### Switching Time:

15 ms maximum

### Operating Temperature:

- 25°C to +65°C (Standard)
- 55°C to +85°C (Extended "T" Option)

### Mechanical Life, Cycles:

1,000,000 minimum

### Vibration, Operating:

10G RMS, 20-2000 Hz

### Mechanical Shock, Non-Operating:

30G, 1/2 Sine, 11 ms

### Nominal Weight:

5.5 oz. (156 g.)

\* Performance varies depending on selected options.

## Mechanical

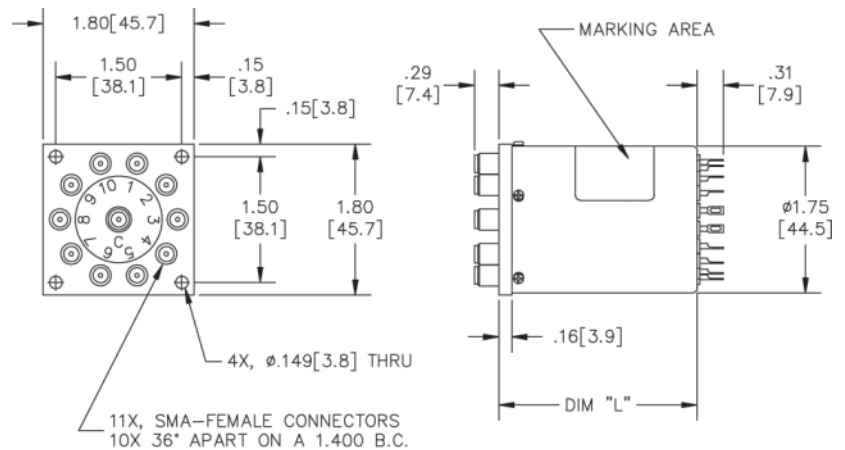

DIM "L" (MAX)	MODEL	ELEC. SCHEM.
1.65 [41.9]	5Z1-5X08	1
2.40 [61.0]	5Z1-5X0822	1
2.25 [57.2]	5Z1-5X0802A	2
2.71 [57.2]	5Z1-5X0822A	2

5A1-530822 Shown

For Electrical Schematic, see page # 3-20

## Part Number Selector

5A1 J - 5 2 08 02 A - ROHS

Special Options	Actuator	Coil Voltage	Connectors	Indicators	Circuit Options
J = 9 or 26 Pin 'D' Connector	5 = Normally Open	2 = 12 Vdc	08 = SMA Female	02 = No Indicators**	A = TTL High
R = (-) Com*	9 = Normally Open Suppression Diodes	3 = 28 Vdc		22 = SPST Indicators	N = CANBus
S = Epoxy Seal		8 = 24 Vdc			
T = -55° to +85° C					

\*\* Declared only with Circuit Options

\* Only available with Normally Open Suppression Diodes

TTL option includes suppression diode. Other options may be available and all combinations may not be possible. Please consult with factory.

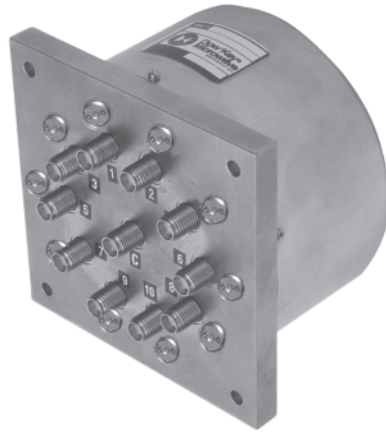

- DC-18 GHz
- Low/Medium Power
- 1M Life Cycles

## RF Characteristics

Frequency GHz	VSWR (max)	Isolation dB (min)	Ins. Loss dB (max)
DC-4	1.20	70	0.20
4-8	1.30	65	0.30
8-12.4	1.40	70	0.40
12.4-18	1.50	60	0.50

Performance may vary depending on selected options

## Specifications

### Operating Voltage:

- 12 Vdc (11-14 Vdc)
- 24 Vdc (20-28 Vdc)
- 28 Vdc (24-32 Vdc)

### Coil Current (max. @ nom. Vdc & 25°C)\*:

- 12 Vdc 345 mA
- 24 Vdc 175 mA
- 28 Vdc 150 mA

### Switching Time:

20 ms maximum

### Operating Temperature:

- 25°C to +65°C (Standard)
- 55°C to +85°C (Extended "T" Option)

### Mechanical Life, Cycles:

1,000,000 minimum

### Vibration, Operating:

10G RMS, 20-2000 Hz

### Mechanical Shock, Non-Operating:

30G, 1/2 Sine, 11 ms

### Nominal Weight\*:

17.5 oz. (496 g.)

\* Performance and weight varies depending on selected options.

## Mechanical

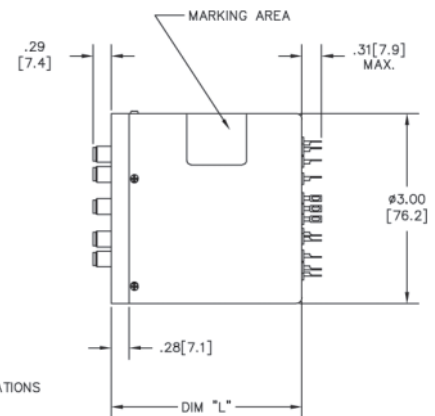
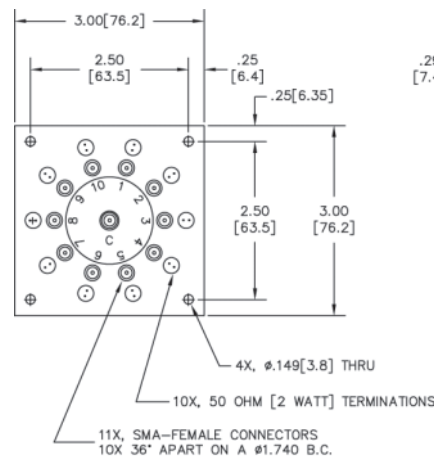

DIM "L" (MAX)	MODEL	ELEC. SCHEM.
1.93 [49.0]	5Z1-5X0803	3
3.00 [76.2]	5Z1-5X0823	3
2.27 [57.6]	5Z1-5X0803A	4
2.80 [71.1]	5Z1-5X0823A	4

5A1-530823 Shown

For Electrical Schematic, see page # 3-20

## Part Number Selector

5A1 J 5- 2 08 03 A RØHS

### Special Options

- J = 15 or 26 Pin 'D' Connector
- R = (-) Com
- S = Epoxy Seal
- T = -55° to +85° C

### Actuator

5 = Normally Open

### Coil Voltage

- 2 = 12 Vdc
- 3 = 28 Vdc
- 8 = 24 Vdc

### Connectors

08 = SMA Female

### Indicators

- 03 = No Indicators  
2W Terminations
- 23 = SPST Indicators  
2W Terminations

### Circuit Options

A = TTL High  
E = BCD Decoding

TTL option includes suppression diode. Other options may be available and all combinations may not be possible. Please consult with factory.





- DC-18 GHz
- Low/Medium Power
- 1M Life Cycles

## RF Characteristics

Frequency GHz	VSWR (max)	Isolation dB (min)	Ins. Loss dB (max)
DC-4	1.20	70	0.20
4-8	1.30	65	0.30
8-12.4	1.40	60	0.40
12.4-18	1.60	55	0.60

Performance may vary depending on selected options

## Specifications

### Operating Voltage:

- 12 Vdc (11-14 Vdc)
- 24 Vdc (20-28 Vdc)
- 28 Vdc (24-32 Vdc)

### Coil Current (max. @ nom. Vdc & 25°C)\*:

- 12 Vdc 440 mA
- 24 Vdc 225 mA
- 28 Vdc 190 mA

### Switching Time\*:

20 ms maximum

### Operating Temperature:

- 25°C to +65°C (Standard)
- 55°C to +85°C (Extended "T" Option)

### Mechanical Life, Cycles:

1,000,000 minimum

### Vibration, Operating:

10G RMS, 20-2000 Hz

### Mechanical Shock, Non-Operating:

30G, 1/2 Sine, 11 ms

### Nominal Weight\*:

15.0 oz. (425 g.)

\* Performance and weight varies depending on selected options.

## Mechanical

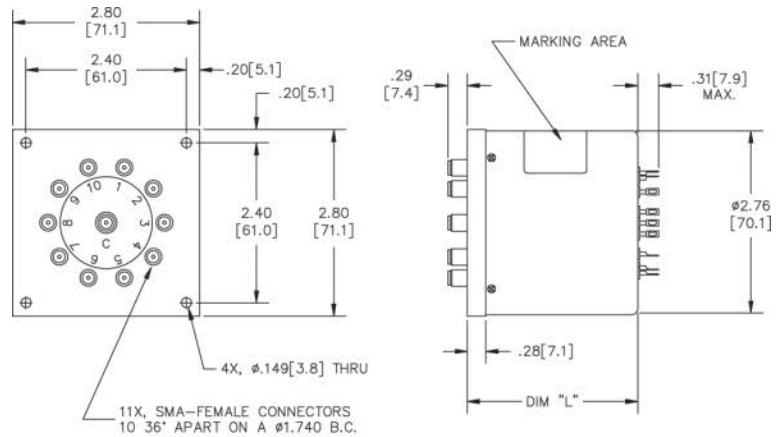

DIM "L" (MAX)	MODEL	ELEC. SCHEM.
3.00 [76.2]	5Z1-4X08	1
3.00 [76.2]	5Z1-4X0822	1
3.00 [76.2]	5Z1-4X0802A	2
3.00 [76.2]	5Z1-4X0822A	2

5A1-430822 Shown

For Electrical Schematic, see page # 3-21

## Part Number Selector

5A1 J - 4 2 08 02 A - ROHS

### Special Options

- J = 9 or 26 Pin 'D' Connector
- P = Power Plug
- R = (-) Com
- S = Epoxy Seal
- T = -55° to +85° C

### Actuator

- 4 = Latching Self Cutoff

### Coil Voltage

- 2 = 12 Vdc
- 3 = 28 Vdc
- 8 = 24 Vdc

### Connectors

- 08 = SMA Female

### Indicators

- 02 = No Indicators\*
- 22 = SPST Indicators

### Circuit Options

- A = TTL High
- E = BCD Decoding

\* Declared only with Circuit Options

TTL option includes suppression diode. Other options may be available and all combinations may not be possible. Please consult with factory.



- DC-18 GHz
- Low/Medium Power
- 1M Life Cycles

## RF Characteristics

Frequency GHz	VSWR (max)	Isolation dB (min)	Ins. Loss dB (max)
DC-4	1.20	70	0.20
4-8	1.30	65	0.30
8-12.4	1.40	60	0.40
12.4-18	1.60	55	0.60

Performance may vary depending on selected options

## Specifications

### Operating Voltage:

- 12 Vdc (11-14 Vdc)
- 24 Vdc (20-28 Vdc)
- 28 Vdc (24-32 Vdc)

### Coil Current (max. @ nom. Vdc & 25°C)\*:

- 12 Vdc 440 mA
- 24 Vdc 225 mA
- 28 Vdc 190 mA

### Switching Time:

20 ms maximum

### Operating Temperature:

- 25°C to +65°C (Standard)
- 55°C to +85°C (Extended "T" Option)

### Mechanical Life, Cycles:

1,000,000 minimum

### Vibration, Operating:

10G RMS, 20-2000 Hz

### Mechanical Shock, Non-Operating:

30G, 1/2 Sine, 11 ms

### Nominal Weight\*:

15 oz. (425 g.)

\* Performance and weight varies depending on selected options.

## Mechanical

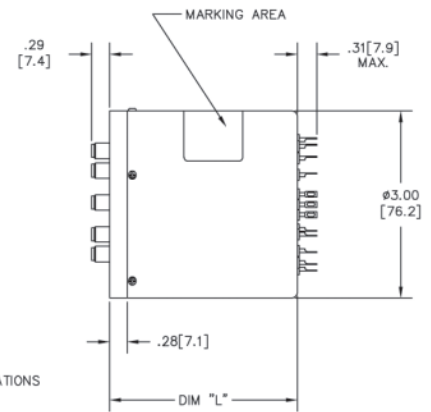
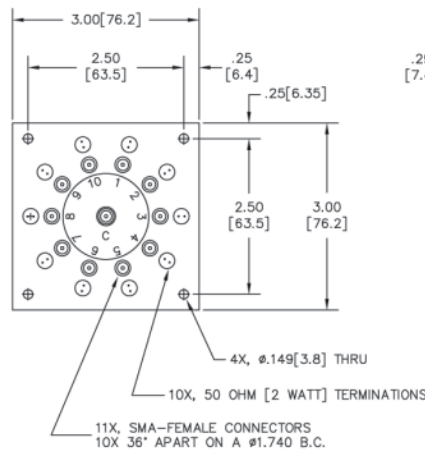

DIM "L" (MAX)	MODEL	ELEC. SCHEM.
2.70 [68.6]	5Z1-4X0803	3
3.00 [76.2]	5Z1-4X0823	3
3.00 [76.2]	5Z1-4X0803A	4
3.00 [76.2]	5Z1-4X0823A	4

5A1-430823 Shown

For Electrical Schematic, see page # 3-21

## Part Number Selector

5A1 J - 4 2 08 03 A - ROHS

### Special Options

- J = 15 or 25 Pin 'D' Connector
- P = Power Plug
- R = (-) Com
- S = Epoxy Seal
- T = -55° to +85° C

### Actuator

- 4 = Latching Self Cutoff

### Coil Voltage

- 2 = 12 Vdc
- 3 = 28 Vdc
- 8 = 24 Vdc

### Connectors

- 08 = SMA Female

### Indicators

- 03 = No Indicators  
2W Terminations
- 23 = SPST Indicators  
2W Terminations

### Circuit Options

- A = TTL High
- E = BCD Decoding

TTL option includes suppression diode. Other options may be available and all combinations may not be possible. Please consult with factory.



- DC-18 GHz
- Low/Medium Power
- 1M Life Cycles

## RF Characteristics

Frequency GHz	VSWR (max)	Isolation dB (min)	Ins. Loss dB (max)
DC-4	1.20	70	0.20
4-8	1.40	65	0.40
8-12.4	1.50	60	0.60
12.4-18	1.80	60	0.80

Performance may vary depending on selected options

## Specifications

### Operating Voltage:

- 12 Vdc (11-14 Vdc)
- 24 Vdc (20-28 Vdc)
- 28 Vdc (24-32 Vdc)

### Coil Current (max. @ nom. Vdc & 25°C)\*:

- 12 Vdc 300 mA
- 24 Vdc 150 mA
- 28 Vdc 135 mA

### Switching Time:

15 ms maximum

### Operating Temperature:

- 25°C to +65°C (Standard)
- 55°C to +85°C (Extended "T" Option)

### Mechanical Life, Cycles:

1,000,000 minimum

### Vibration, Operating:

10G RMS, 20-2000 Hz

### Mechanical Shock, Non-Operating:

30G, 1/2 Sine, 11 ms

### Nominal Weight\*:

7.0 oz. (198 g.)

\* Performance and weight varies depending on selected options.

## Mechanical

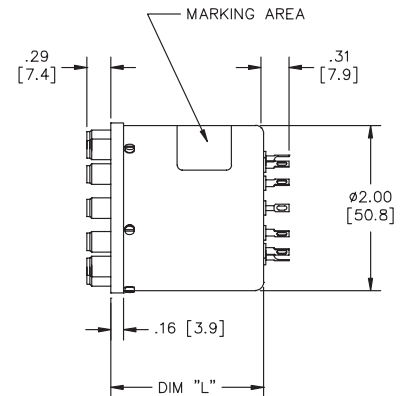
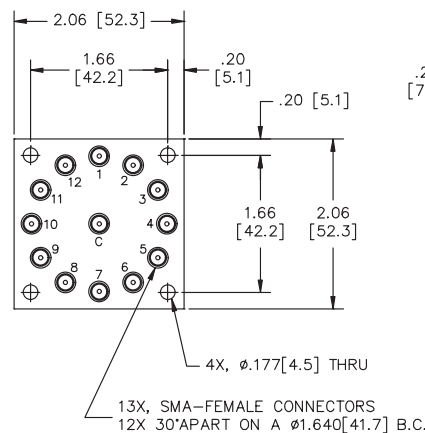

DIM "L" (MAX)	MODEL	ELEC. SCHEM.
1.65 [41.9]	5C1-5X08	1
2.50 [63.5]	5C1-5X0802A	2

5C1-5X0822 Shown

For Electrical Schematic, see page # 3-20

## Part Number Selector

5C1 J - 5 2 08 02 A - ROHS

Special Options	Actuator	Coil Voltage	Connectors	Indicators	Circuit Options
J = 15 or 25 Pin 'D' Connector	5 = Normally Open	2 = 12 Vdc	08 = SMA Female	02 = No Indicators*	A = TTL High
S = Epoxy Seal	9 = Normally Open Suppression Diodes	3 = 28 Vdc		22 = SPST Indicators	E = BCD Decoding
T = -55° to +85° C		8 = 24 Vdc			N = CANBus

\* Declared only with Circuit Options

TTL option includes suppression diode. Other options may be available and all combinations may not be possible. Please consult with factory.



- DC-18 GHz
- Low/Medium Power
- 1M Life Cycles

## RF Characteristics

Frequency GHz	VSWR (max)	Isolation dB (min)	Ins. Loss dB (max)
DC-4	1.20	70	0.20
4-8	1.40	65	0.40
8-12.4	1.50	60	0.60
12.4-18	1.80	60	0.80

Performance may vary depending on selected options

## Specifications

### Operating Voltage:

- 12 Vdc (11-14 Vdc)
- 24 Vdc (20-28 Vdc)
- 28 Vdc (24-32 Vdc)

### Coil Current (max. @ nom. Vdc & 25°C)\*:

- 12 Vdc 650 mA
- 24 Vdc 500 mA
- 28 Vdc 500 mA

### Switching Time\*:

30 ms maximum

### Operating Temperature:

- 25°C to +65°C (Standard)
- 55°C to +85°C (Extended "T" Option)

### Mechanical Life, Cycles:

1,000,000 minimum

### Vibration, Operating:

10G RMS, 20-2000 Hz

### Mechanical Shock, Non-Operating:

30G, 1/2 Sine, 11 ms

### Nominal Weight\*:

17.5 oz. (496 g.)

\* Performance and weight varies depending on selected options.

## Mechanical

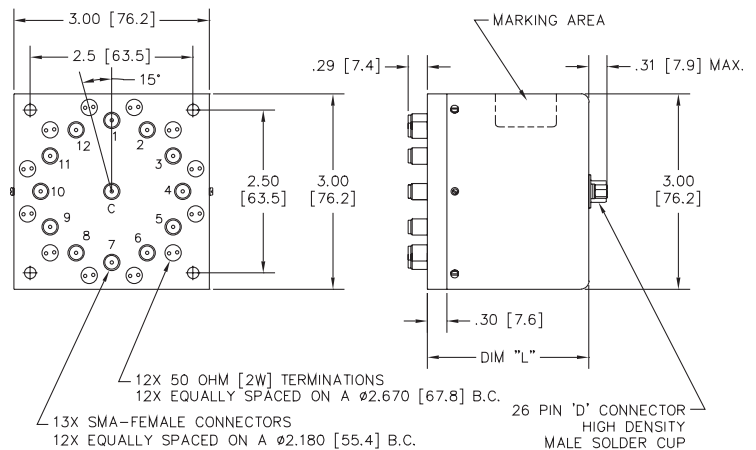

DIM "L" (MAX)	MODEL	ELEC. SCHEM.
2.85 [72.4]	5C1-4X0803	3
3.00 [76.2]	5C1-4X0803A	4
3.85 [97.8]	5C1J-4X0803A	4

5C1J-4X0803A Shown  
For Electrical Schematic, see page # 3-21

## Part Number Selector

5C1 J - 4 2 08 02 A - ROHS

### Special Options

- J = 15 or 25 Pin 'D' Connector
- S = Epoxy Seal
- T = -55° to +85° C

### Actuator

- 4 = Latching Self Cutoff

### Coil Voltage

- 2 = 12 Vdc
- 3 = 28 Vdc
- 8 = 24 Vdc

### Connectors

- 08 = SMA Female

### Indicators

- 02 = No Indicators\*
- 03 = No Indicators  
2W Terminations
- 53 = SPST Indicators  
2W Terminations\*\*

### Circuit Options

- A = TTL High
- E = BCD Decoding
- N = CANBus

\* Declared only with Circuit Options

\*\* Only used with CANBus Option

TTL option includes suppression diode. Other options may be available and all combinations may not be possible. Please consult with factory.



- DC-18 GHz
- Low/Medium Power
- 1M Life Cycles

## RF Characteristics

Frequency GHz	VSWR (max)	Isolation dB (min)	Ins. Loss dB (max)
DC-4	1.30	70	0.30
4-8	1.40	65	0.41
8-12	1.60	60	0.60
12-18	2.00	55	1.00

Performance may vary depending on selected options

## Specifications

### Operating Voltage:

- 12 Vdc (11-14 Vdc)
- 24 Vdc (20-28 Vdc)
- 28 Vdc (24-32 Vdc)

### Coil Current (max. @ nom. Vdc & 25°C)\*:

- 12 Vdc 300 mA
- 24 Vdc 160 mA
- 28 Vdc 135 mA

### Switching Time:

20 ms maximum

### Operating Temperature:

- 25°C to +65°C (Standard)
- 55°C to +85°C (Extended "T" Option)

### Mechanical Life, Cycles:

1,000,000 minimum

### Vibration, Operating:

10G RMS, 20-2000 Hz

### Mechanical Shock, Non-Operating:

50G, 1/2 Sine, 11 ms

### Nominal Weight\*:

20.0 oz. (198 g.)

\* Performance and weight varies depending on selected options.

## Mechanical

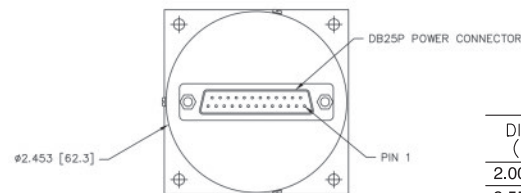
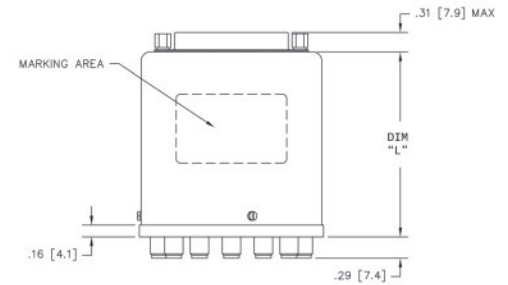
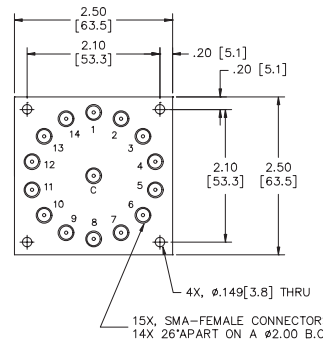

DIM "L" (MAX)	MODEL	ELEC. SCHEM.
2.00 [50.8]	5E1J-5X08	1
2.55 [64.8]	5E1J-5X0802A	2

5E1J-5X0802A Shown  
For Electrical Schematic, see page # 3-20

## Part Number Selector

5E1 J - 5 2 08 02 A ROHS

### Special Options

- J = 15 or 25 Pin 'D' Connector
- S = Epoxy Seal
- T = -55° to +85° C

### Actuator

5 = Normally Open

### Coil Voltage

- 2 = 12 Vdc
- 3 = 28 Vdc
- 8 = 24 Vdc

### Connectors

08 = SMA Female

### Indicators

02 = No Indicators\*

### Circuit Options

- A = TTL High
- E = BCD decoding

\* Declared only with Circuit Options

TTL option includes suppression diode. Other options may be available and all combinations may not be possible. Please consult with factory.

### 01 Normally Open

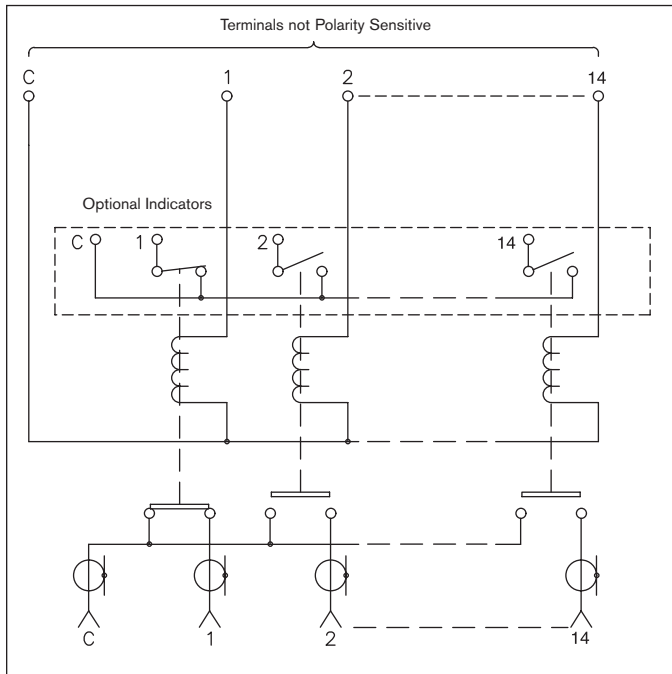

### 02 Normally Open TTL

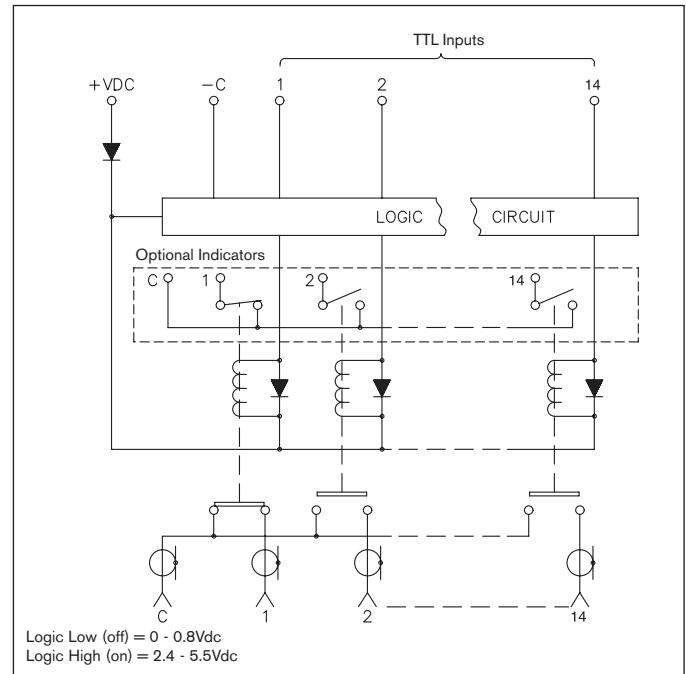

### 03 Normally Open Terminated

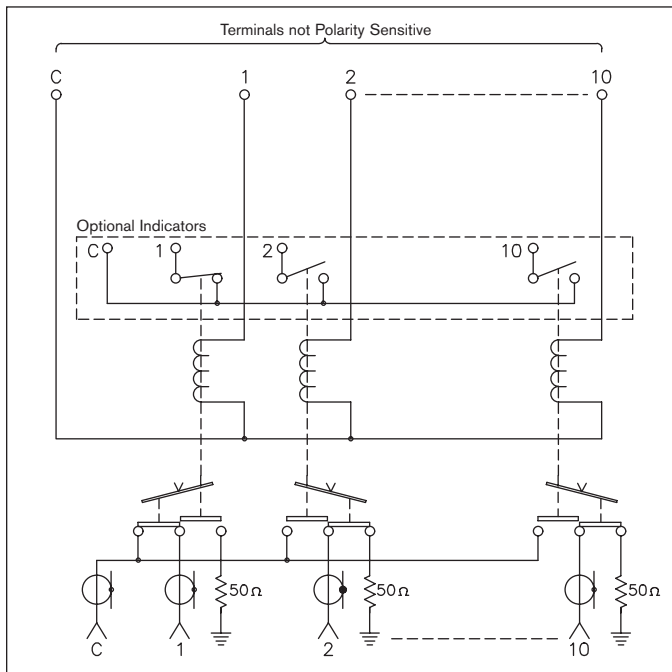

### 04 Normally Open Terminated TTL

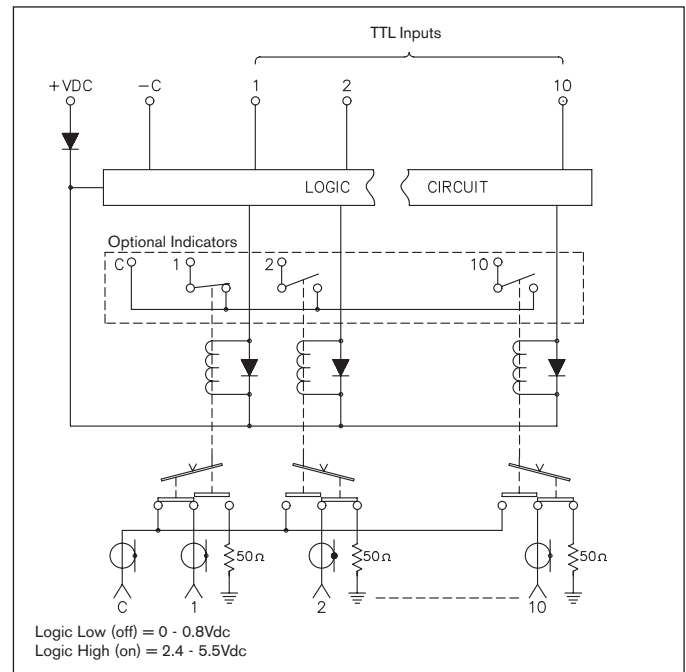

01 Latching Self Cutoff

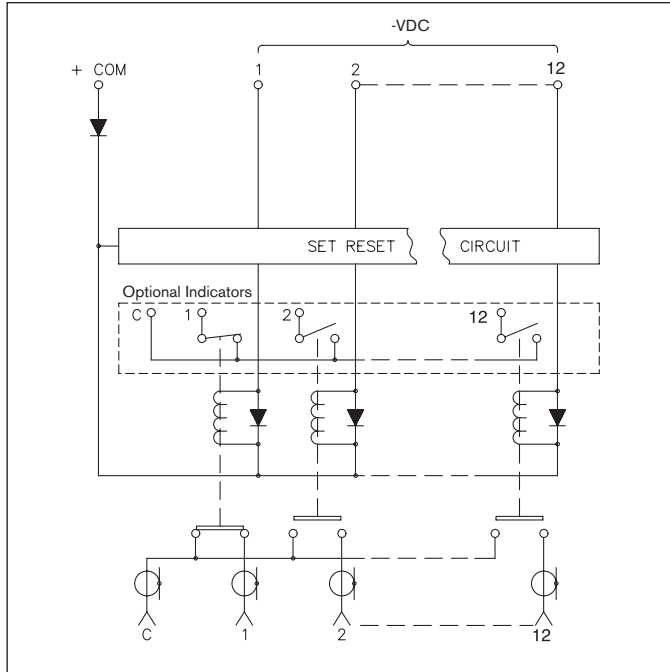

02 Latching Self Cutoff TTL

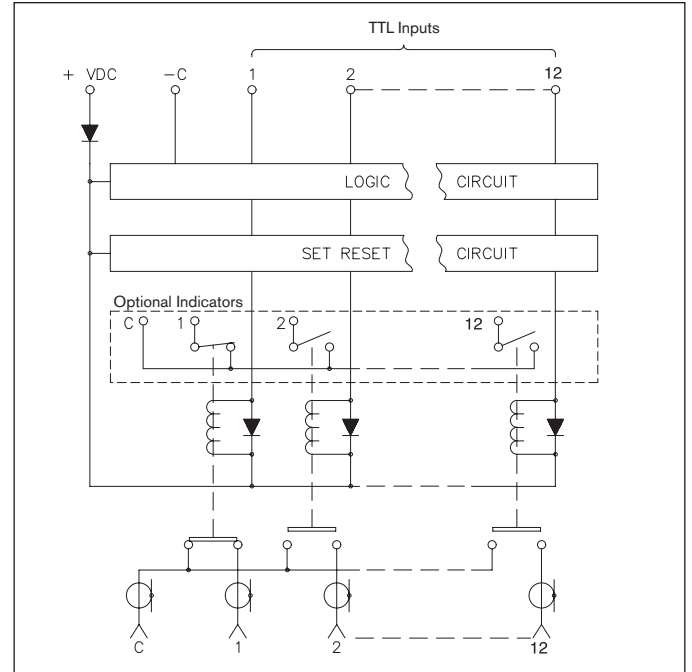

03 Latching Self Cutoff Terminated

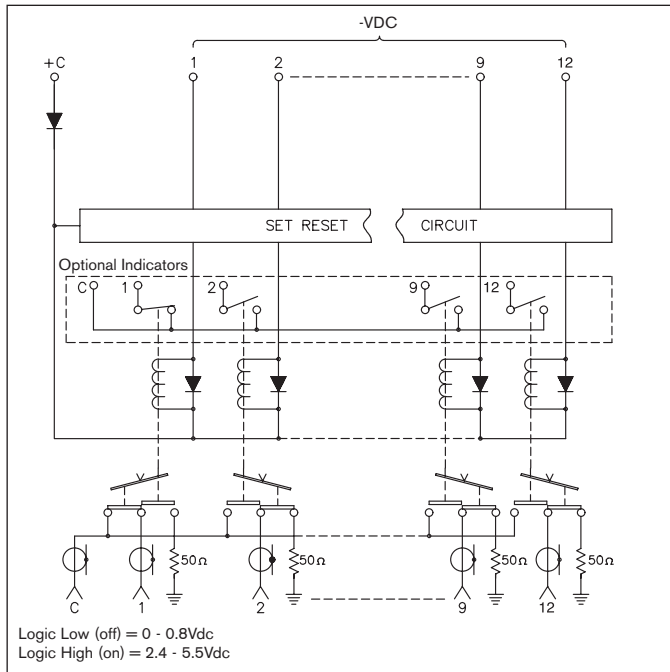

04 Latching Self Cutoff Terminated TTL

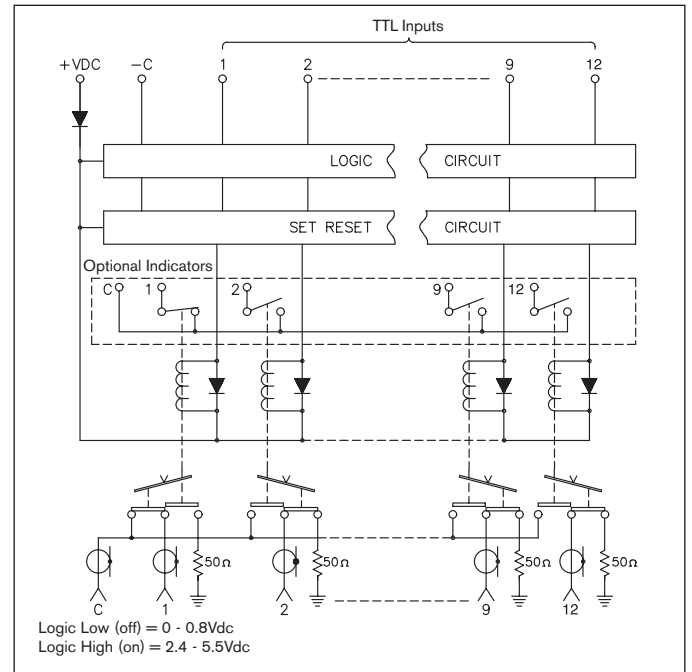

# **HIGH REPEATABILITY RELIANT™ COAXIAL SWITCH**

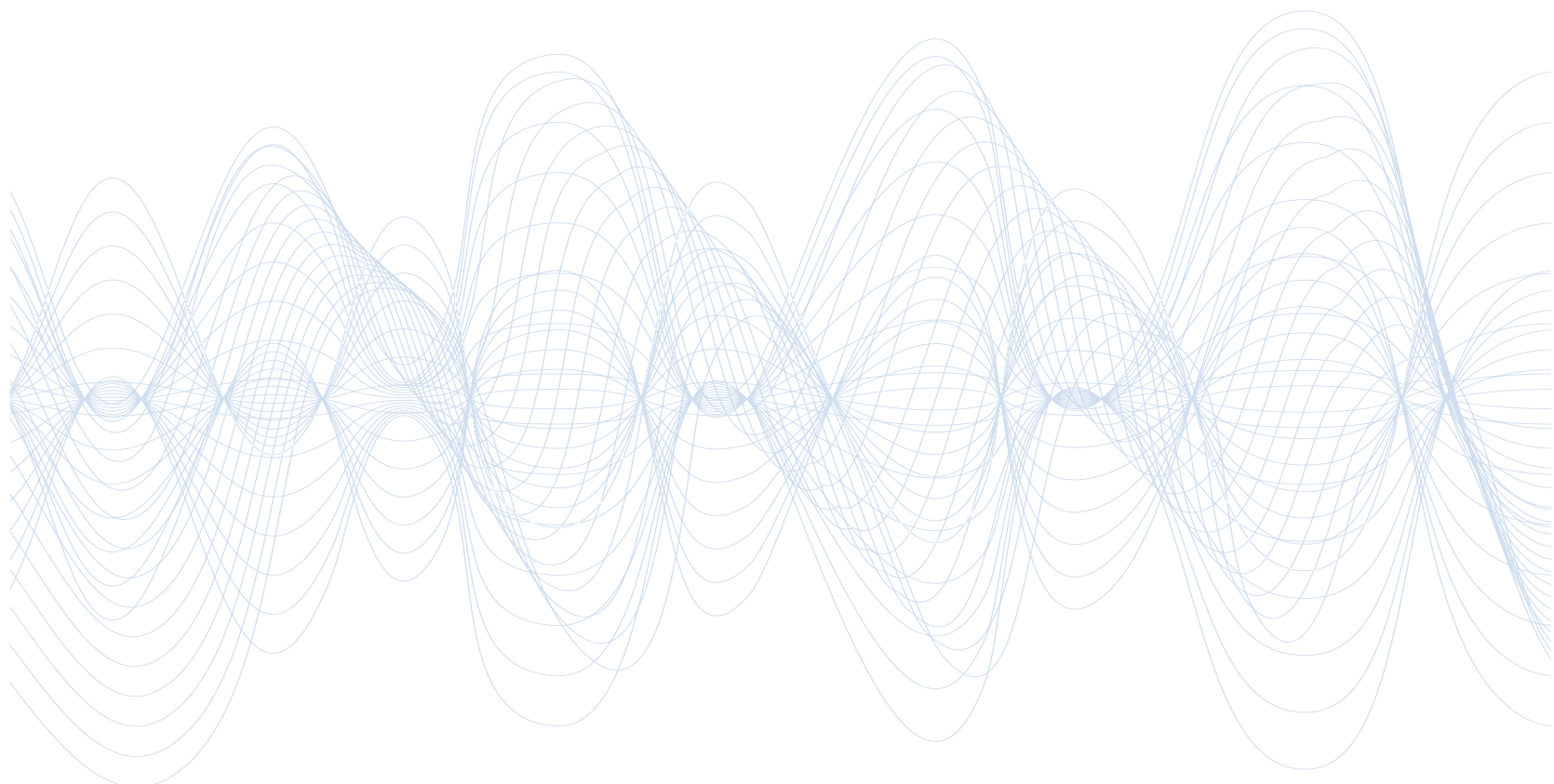



## RF Characteristics



- High Repeatability
- DC-26.5 GHz
- 0.03 dB Insertion Loss Repeatability @ 25°C
- 5M Life Cycles

Frequency GHz	VSWR (max)	Isolation dB (min)	Ins. Loss dB (max)
DC-4	1.20	100	0.36*
4-12.4	1.35	80	0.49*
12.4-18	1.45	70	0.57*
18-26.5	1.70	65	0.68*

\* Value calculated as follows:  $0.015 \times \text{Frequency [GHz]} + 0.3$

## Specifications

### Operating Voltage (across temperature range):

- 12 Vdc (11-14 Vdc)
- 24 Vdc (20-32 Vdc)

### Coil Current (max. @ nom. Vdc & 25°C):

- 12 Vdc Consult with factory
- 24 Vdc 195 mA

### Stand-By Current (nom. Vdc @ 25°C):

- CANBus: 12 Vdc 35 mA
- TTL: 24 Vdc 26 mA

### Stand-By Current (typ. Vdc @ 25°C):

- CANBus: 32-41 mA
- TTL: 23-30 mA

### Switching Time:

15 ms maximum

### Operating Temperature:

-25°C to +75°C

### Storage Temperature:

-55°C to +85°C

### Mechanical Life Cycles:

5,000,000 minimum

### Vibration, Operating:

7G RMS, 20-2000 Hz

### Nominal Weight:

8.8 oz. (250 g.)

## Mechanical

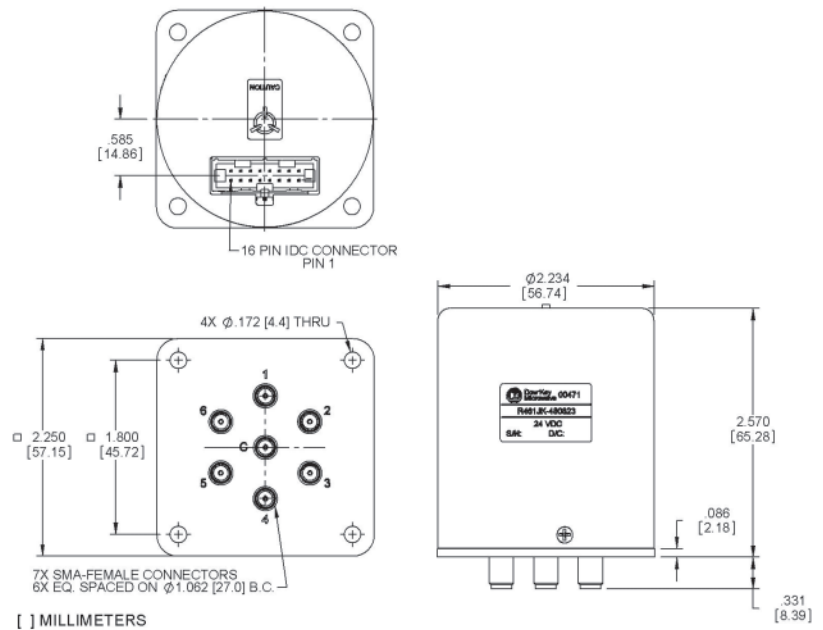

## Part Number Selector

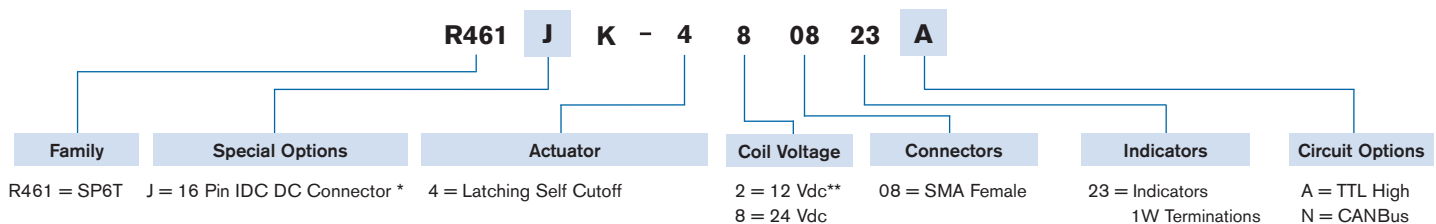

\* Not used with CANBus option  
 \*\* Available with CANBus option only

# LOW PIM COAXIAL SWITCH

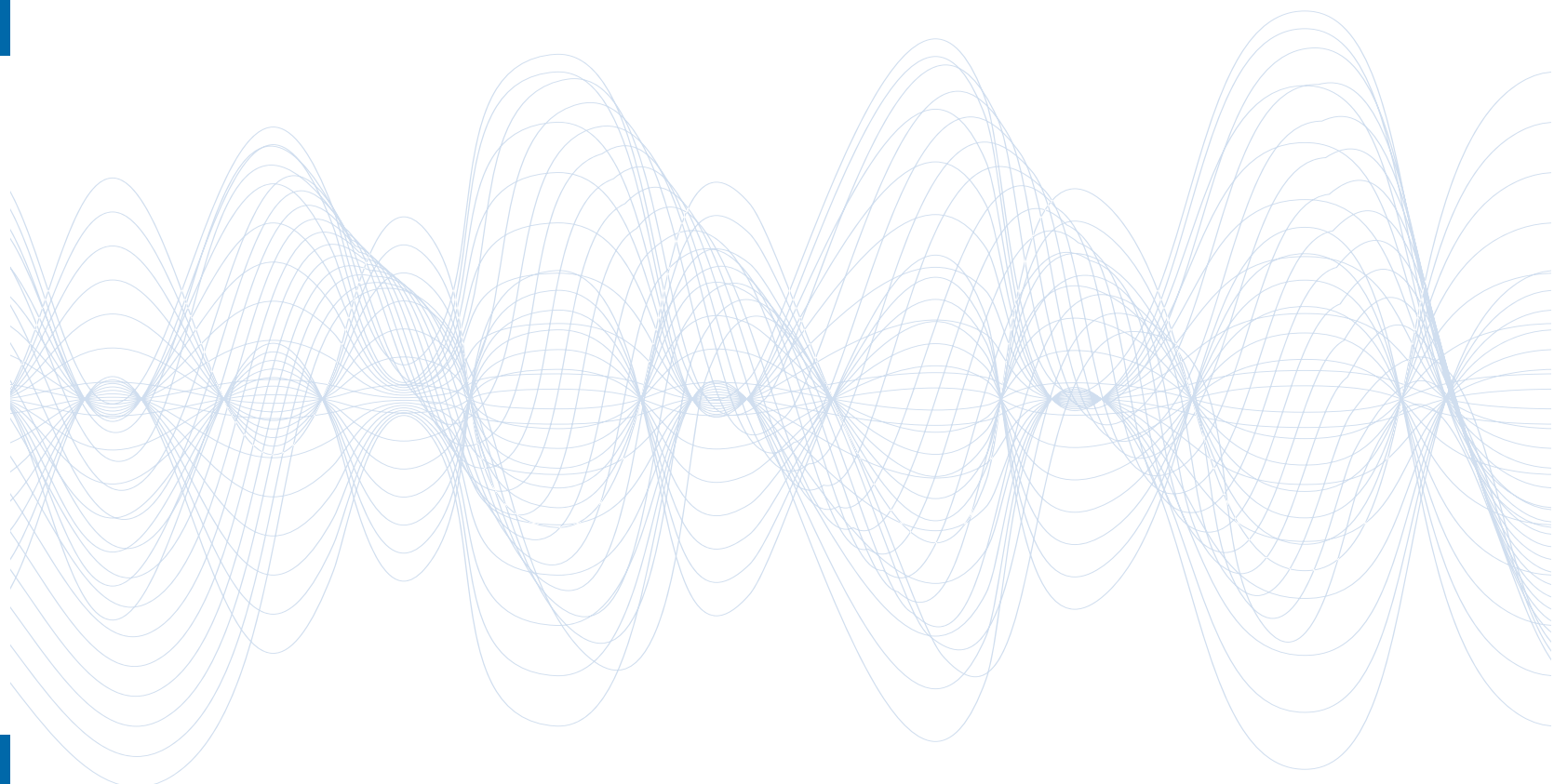

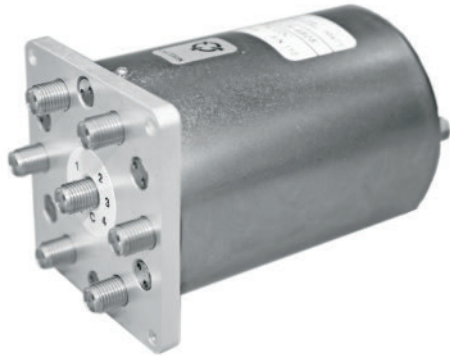

- DC-18 GHz
- Below -160 dBc
- RoHS Compliant
- Low/Medium Power
- 1M Life Cycles

## Standard Options

Switch Type	Part Number	"D" Connector	Indicator
SPDT	401JW-4X08-ROHS	9 Pin	No
SPDT	401JW-4X0832-ROHS	9 Pin	Yes
DPDT	411CJW-4X08-ROHS	9 Pin	No
DPDT	411CJW-4X0832-ROHS	9 Pin	Yes
SP6T	461JLW-4X08-ROHS	15 Pin	No
SP6T	461JLW-4X0822-ROHS	15 Pin	Yes
SP8T	581JW-4X08-ROHS	25 Pin	No
SP8T	581JW-4X0822-ROHS	25 Pin	Yes
SP12T	5C1JW-4X08-ROHS	37 Pin	No
SP12T	5C1JW-4X0852-ROHS	37 Pin	Yes

Note: X = 12 or 28 Vdc. Other options may be available. Please consult with the factory.

## Specifications

### Operating Voltage (across temperature range):

12 Vdc (11-14 Vdc)  
28 Vdc (24-32 Vdc)

### Coil Current (max. @ nom. Vdc & 25°C)\*:

SPDT: 12 Vdc 75 mA  
28 Vdc 120 mA  
DPDT: 12 Vdc 250 mA  
28 Vdc 180 mA  
SP6T: 12 Vdc 570 mA  
28 Vdc 180 mA  
SP8T: 12 Vdc 415 mA  
28 Vdc 180 mA  
SP12T: 12 Vdc 650 mA  
28 Vdc 500 mA

### Switching Time:

SPDT, SP6T & SP8T: 15 ms maximum  
DPDT: 20 ms maximum  
SP12T: 30 ms maximum

### Operating Temperature:

-25°C to +65°C (Standard)

### Mechanical Life Cycles:

1,000,000 minimum

### Vibration, Operating:

10G RMS, 20-2000 Hz

### Mechanical Shock, Non-Operating:

30G, 1/2 Sine, 11 ms

### Nominal Weight\*:

SPDT: 1.7 oz. (48 g.)  
DPDT: 3.8 oz. (108 g.)  
SP6T: 8.5 oz. (240 g.)  
SP8T: 10.5 oz. (298 g.)  
SP12T: 18.0 oz. (510 g.)

\* Performance and weight may vary. Please consult with the factory.

## RF Characteristics

### SPDT

Frequency GHz	VSWR (max)	Isolation dB (min)	Ins. Loss dB (max)	RF Power (Watts) *
DC-1	1.10	85	0.10	200
1-4	1.15	80	0.15	150
4-8	1.20	70	0.20	125
8-12	1.30	65	0.30	75
12-18	1.35	60	0.35	60

### DPDT

Frequency GHz	VSWR (max)	Isolation dB (min)	Ins. Loss dB (max)	RF Power (Watts) *
DC-1	1.10	85	0.10	200
1-4	1.20	80	0.20	150
4-8	1.30	70	0.30	125
8-12	1.40	65	0.40	75
12-18	1.50	60	0.50	60

### SP6T & SP8T

Frequency GHz	VSWR (max)	Isolation dB (min)	Ins. Loss dB (max)	RF Power (Watts) *	
				SP6T	SP8T
DC-4	1.20	85	0.20	100	100
4-8	1.30	75	0.30	50	70
8-12.4	1.40	70	0.40	35	60
12.4-18	1.50	60	0.50	25	50

### SP12T

Frequency GHz	VSWR (max)	Isolation dB (min)	Ins. Loss dB (max)	RF Power (Watts) *
DC-4	1.20	70	0.20	100
4-8	1.40	65	0.40	70
8-12.4	1.50	60	0.60	60
12.4-18	1.80	60	0.80	50

\* RF Power (Watts CW MAX)



- DC-12.4 GHz
- Below -160 dBc
- RoHS Compliant
- Low/Medium Power
- 1M Life Cycles

## Standard Options

Switch Type	Part Number	"D" Connector	Indicator
SPDT	402JW-4X01-ROHS	9 Pin	No
SPDT	402JW-4X0132-ROHS	9 Pin	Yes
DPDT	412JW-4X01-ROHS	9 Pin	No
DPDT	412JW-4X0132-ROHS	9 Pin	Yes
SP6T	561JW-4X01-ROHS	15 Pin	No
SP6T	561JW-4X0122-ROHS	15 Pin	Yes

Note: X = 12 or 24 Vdc. Other options may be available. Please consult with factory.

## Specifications

### Operating Voltage (across temperature range):

12 Vdc (11-14 Vdc)  
24 Vdc (20-28 Vdc)

### Coil Current (max. @ nom. Vdc & 25°C)\*:

SPDT: 12 Vdc 320 mA  
24 Vdc 180 mA  
DPDT: 12 Vdc 250 mA  
24 Vdc 240 mA  
SP6T: 12 Vdc 550 mA  
24 Vdc 275 mA

### Switching Time:

SPDT: 20 ms maximum  
DPDT: 20 ms maximum  
SP6T: 20 ms maximum

### Operating Temperature:

-25°C to +65°C (Standard)

### Mechanical Life Cycles:

1,000,000 minimum

### Vibration, Operating:

10G RMS, 20-2000 Hz

### Mechanical Shock, Non-Operating:

30G, 1/2 Sine, 11 ms

### Nominal Weight\*:

SPDT: 6.5 oz. (184 g.)  
DPDT: 8.5 oz. (241 g.)  
SP6T: 17.0 oz. (482 g.)

\* Performance and weight may vary. Please consult with the factory.

## RF Characteristics

### SPDT

Frequency GHz	VSWR (max)	Isolation dB (min)	Ins. Loss dB (max)	RF Power (Watts) *
DC-1	1.15	85	0.15	600
1-2	1.20	80	0.20	400
2-4	1.25	70	0.25	300
4-8	1.45	60	0.40	200
8-12.4	1.50	60	0.50	175

### DPDT

Frequency GHz	VSWR (max)	Isolation dB (min)	Ins. Loss dB (max)	RF Power (Watts) *
DC-1	1.15	85	0.15	200
1-2	1.20	80	0.20	150
2-4	1.25	70	0.25	125
4-8	1.45	60	0.40	75
8-12.4	1.60	60	0.60	60

### SP6T

Frequency GHz	VSWR (max)	Isolation dB (min)	Ins. Loss dB (max)	RF Power (Watts) *
DC-4	1.25	70	0.30	175
4-8	1.35	60	0.40	125
8-12.4	1.70	55	0.70	100

\* RF Power (Watts CW MAX)

# MINIATURE COAXIAL SWITCH

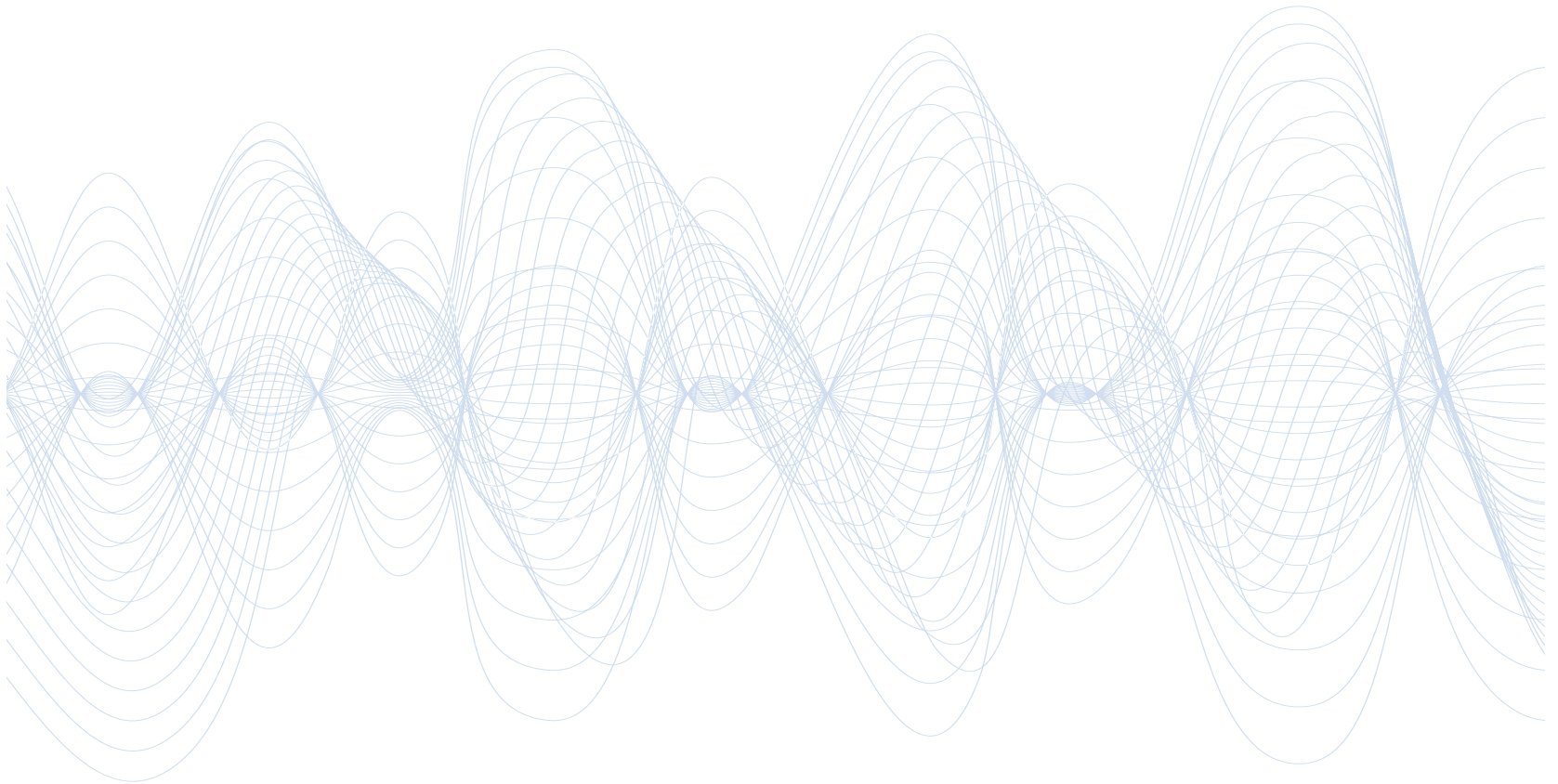



- DC-18 GHz
- Low Power
- 1M Life Cycles

## RF Characteristics

Frequency GHz	VSWR (max)	Isolation dB (min)	Ins. Loss dB (max)	RF Power Watts (CW)
DC-1	1.10	85	0.10	100
1-4	1.20	80	0.20	50
4-8	1.30	70	0.30	35
8-12	1.40	65	0.40	25
12-18	1.50	60	0.50	10

## Specifications

### Operating Voltage:

24 Vdc (20-28 Vdc)

### Coil Current (max. @ nom. Vdc & 25°C)\*:

12 Vdc 320 mA  
 24 Vdc 160 mA  
 28 Vdc 140 mA

### Switching Time:

15 ms maximum

### Operating Temperature:

-55 °C to +85°C

### Mechanical Life Cycles:

1,000,000 minimum

### Vibration, Operating:

10G RMS, 20-2000 Hz

### Mechanical Shock, Non-Operating:

30G, 1/2 Sine, 11 ms

### Nominal Weight:

3.0 oz. (85 g.)

\* Performance varies depending on selected options.

## Mechanical

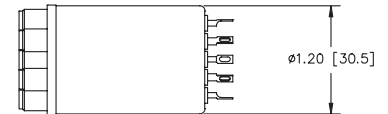
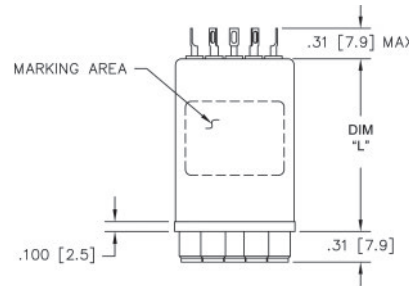

DIM "L" (MAX)	MODEL	ELEC. SCHEM.
1.75 [44.5]	5X7-5X08	1
2.15 [54.6]	5X7-5X0802A	2

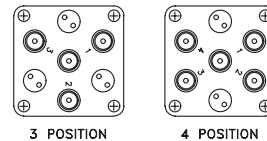

567-5X08 Shown

## Part Number Selector

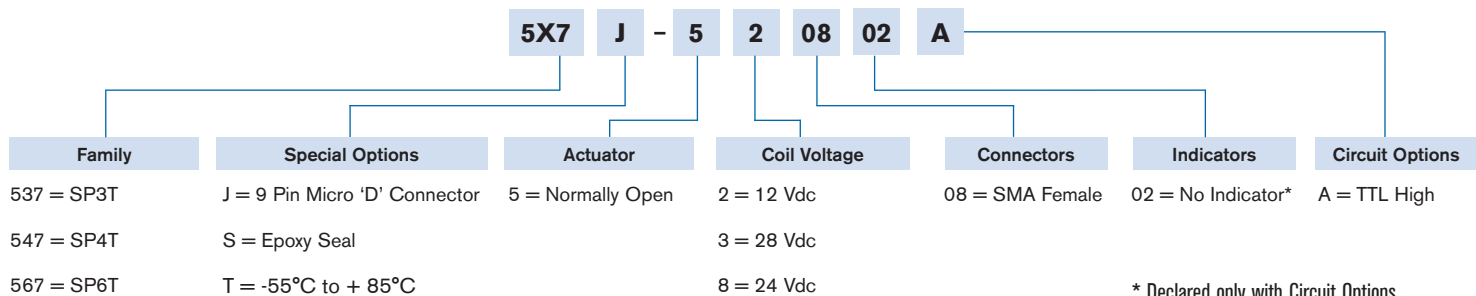

# WAVEGUIDE

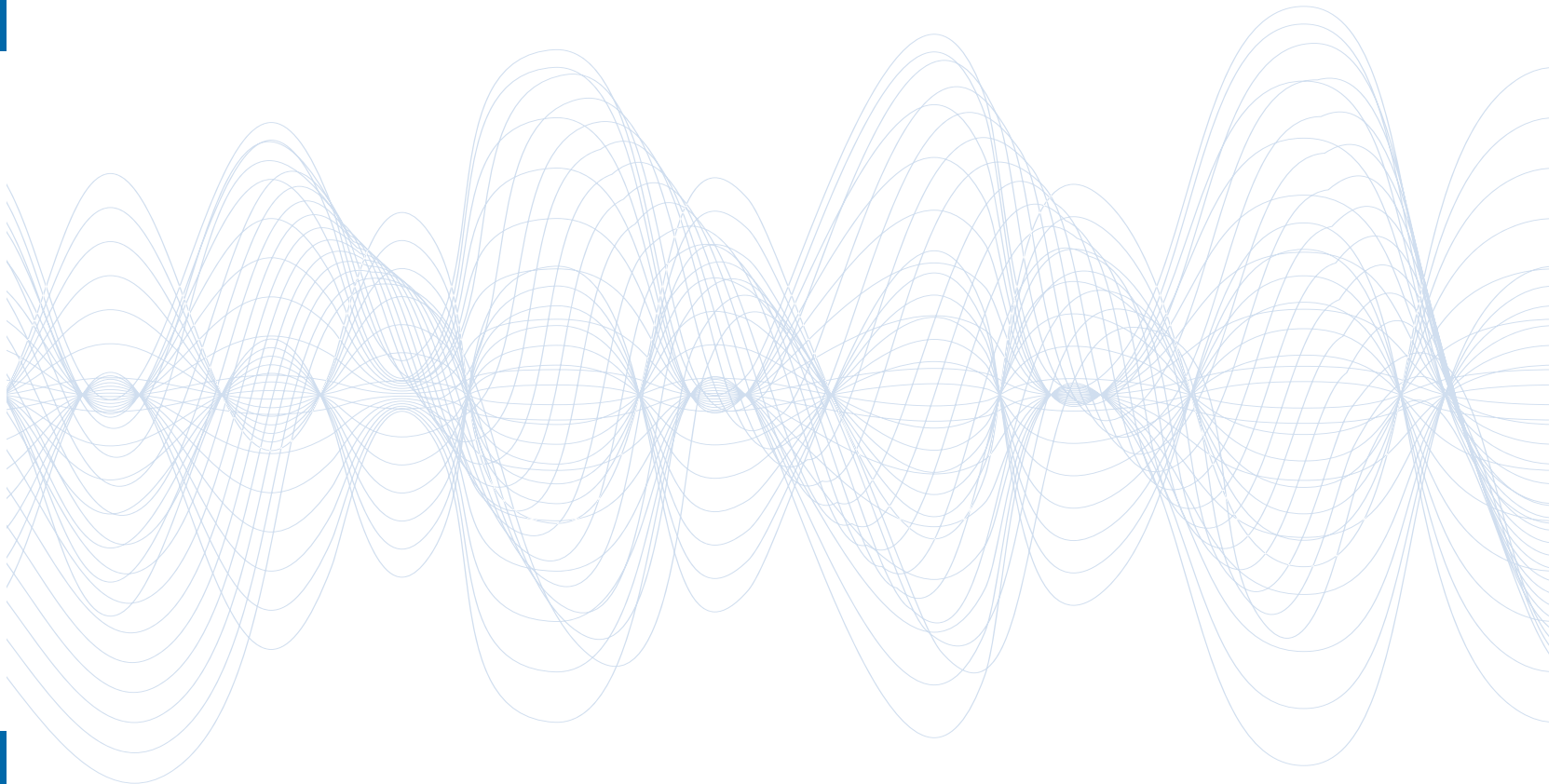



- WR 28 - WR 112
- 200K Cycles
- Reduced Weight
- Reduced Current Consumption

## RF Characteristics

Frequency GHz	VSWR (max)	Isolation dB (min)	Ins. Loss dB (max)
WR 28 (26.5-40.0)	1.12	60	0.20
WR 34 (22.0-33.0)	1.12	60	0.15
WR 42 (18.0-26.5)	1.13	60	0.12
WR 62 (12.4-18.0)	1.10	60	0.10
WR 75 (10.0-15.0)	1.15	60	0.10
WR 90 (8.20-12.4)	1.15	60	0.10
WR 112 (7.05-10.0)	1.10	60	0.10

## Specifications

### Operating Voltage:

28 Vdc (24-30 Vdc)

### Coil Current (max. @ nom. Vdc & 20°C)\*:

28 Vdc 350 mA

### Switching Time:

100 ms maximum (WR 28 thru WR 90)

200 ms maximum (WR 112)

### Operating Temperature:

-54°C to +85°C

### Mechanical Life Cycles:

200,000 minimum

### Nominal Weight:

10.58 oz. (300 g.) for WR 28 thru WR 90

17.64 oz. (500 g.) for WR 112

## Mechanical / Electrical Schematic

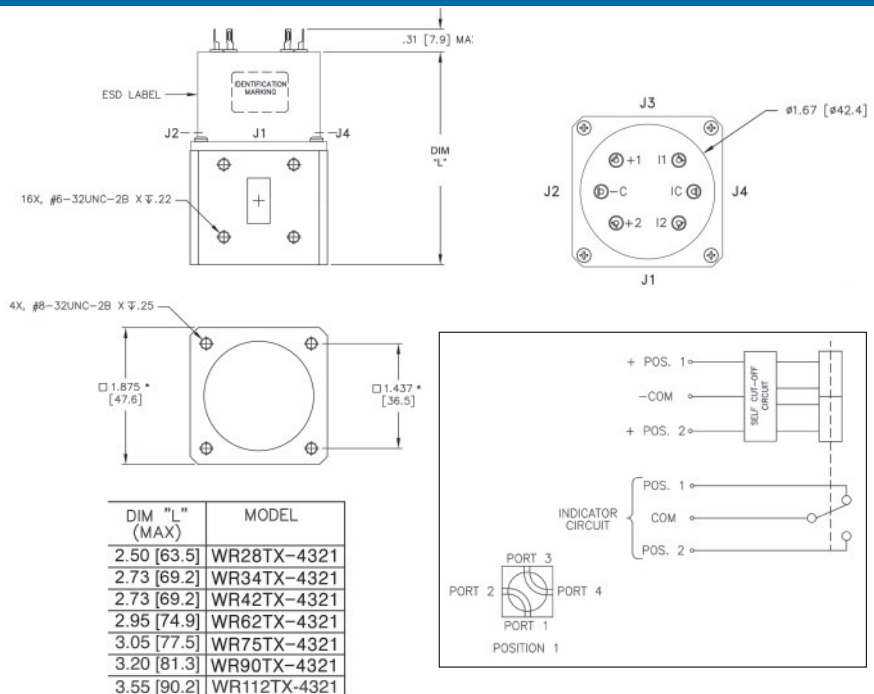

Dimensions are the same for WR 28 thru WR 90 but slightly larger for WR 112.

## Part Number Selector

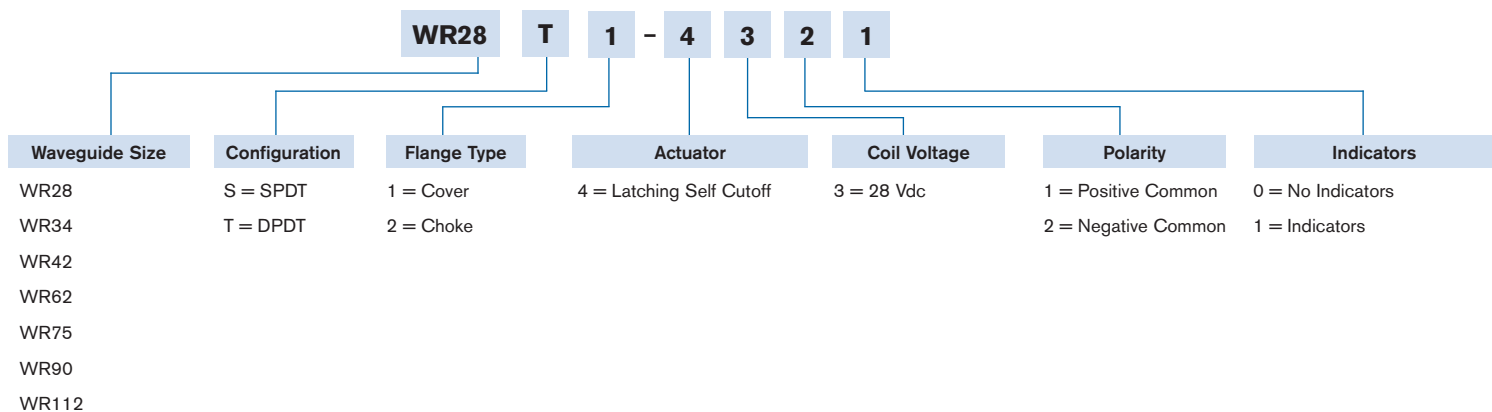



# SWITCH MATRIX & SPACE PRODUCTS CAPABILITY GUIDE

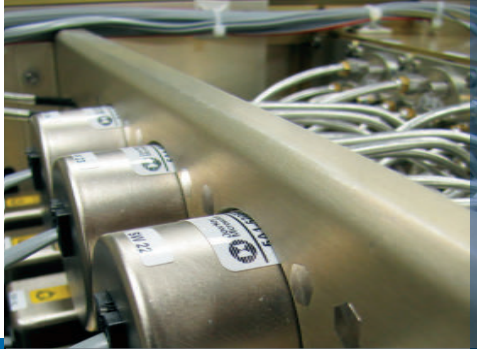
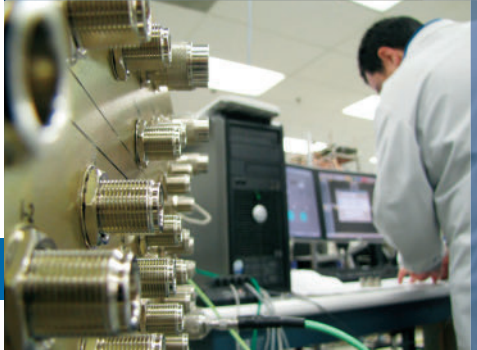

**OUR EXPERTISE, YOUR SWITCH SOLUTION  
SINCE 1945**

# BETTER.FASTER.MODULAR NEXT GENERATION MATRIX

Commerical-Off-The-Shelf {COTS} solutions supporting the aerospace, military, transportation, and communication industries for signal routing and ATE applications.

- Highly scalable and modular
- Trouble-free maintenance for field upgrades & repair
- 1RU/2RU/3RU/4RU rack mountable enclosures
- LCD/Keypad or Touch Screen manual control
- Remote controls:  
*Ethernet (TCP/IP) with HTTP Server or SNMP v1/v2  
or GPIB & RS-232 and USB port*



## Electromechanical Switching Systems

*DC to 40 GHz  
Faster switching time at system level  
Keeps track of the life of each switch  
All electronic components are RoHS compliant  
Field upgradable firmware via boot loader  
Switches can be mixed & matched  
Configured either as a MUX, a Crossbar or individual switches  
Normally Open & Latching switches  
Terminated or non-terminated solutions*

## Fiber Optic Matrix



*C-band  
Switching in Optical Domain  
Fan-Out / Crossbar  
16x16 Matrix, LCD Touch Screen & Ethernet remote control*

## Solid State Matrix



*HF to S-band  
6x6 to 12x16 unidirectional, redundant power supplies,  
removable hard drive, LCD Touch Screen & Ethernet remote control*

## MS-Control Kit Do-It-Yourself (DIY)

Software control via RS-232, USB with either GPIB or Ethernet (TCP/IP) & HTTP Server. Controls up to 20 Dow-Key CAN Bus switches. Expansion cards available as an option

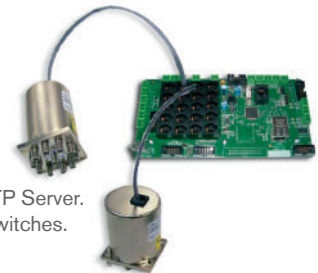

## Integrated Switching Systems & Custom Solutions



*C-band  
Full Rack Modular Solution  
16x32 expandable to 32x64  
Non-Blocking Full Fan-Out  
Manual and Remote Control*

*L-band  
Duplex Transmitter & Receiver Racks  
12x48 Fan-Out & 48x12 Fan-In Solution  
Equipped with signal monitor panels, fiber optic receiver, amplifiers, switching modules, master & slave controller.  
Manual and Remote Control*

*Systems are fully controlled through controller module(s) with Windows based PC and removable hard drive.*



*L-band  
4x48 Solid State Fan-Out Switch  
48x4 Solid State Fan-In Switch  
8x2 Electromechanical Switch  
LCD Touch Screen  
Ethernet with SNMP protocol*

**More info at [http://www.dowkey.com/matrix\\_catalog.php](http://www.dowkey.com/matrix_catalog.php)**

# OUR HERITAGE, YOUR SWITCH SOLUTION

Space business experts stress the three most critical aspects of supplier selection: **heritage, heritage, heritage.**



**411HQ DPDT**



**421H SPDT**

Our lightweight (less than 55 grams) and highly reliable qualified transfer switches are used in programs such as Inmarsat-4 and Galileo satellite systems.

Innovative and proven high reliability SPDT switches have played a part in hundreds of successful space missions.



**High Power T-Switch**

Dow-Key distinguishes itself by introducing random drive T-Switches, which minimizes the switching time rather than forcing the application to switch RF paths in sequential order. Qualified on INSAT-3 MUOS, G-SAT and TDRS programs.

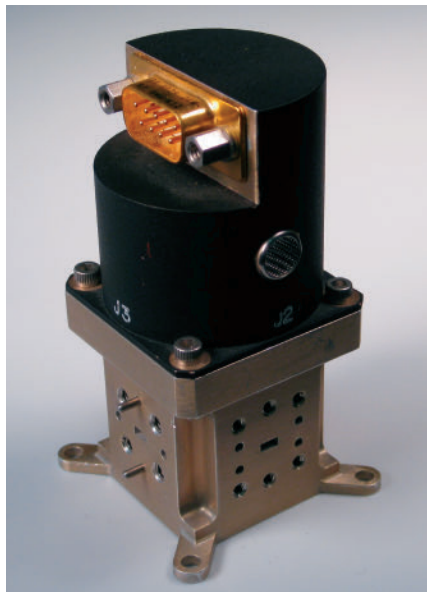

**WR-15**

Dow-Key WR/G is used in high profile space mission such as Kepler (flight system) and Deep Impact (NASA space probe).

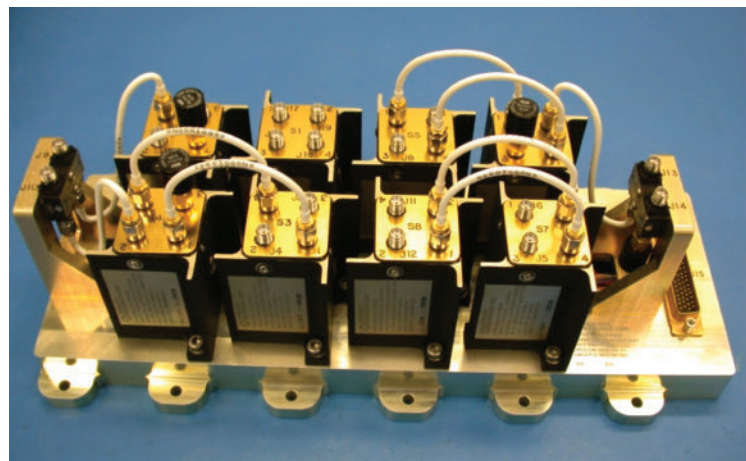

Dow-Key's outstanding HI-Rel track record has evolved in combining space qualified switches and other components such as power dividers in a block of switches to achieve the matrix complexity needed in programs such as GPS, GOES, Inmarsat-4, and other programs.

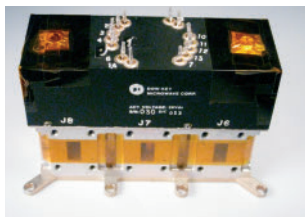

**222D-Series**

More info at [http://www.dowkey.com/space\\_brochure.php](http://www.dowkey.com/space_brochure.php)